

CATALOG
2021



HYDRO

**CAR WASH
EQUIPMENT**
100% MADE IN ITALY

01 ASPIRATORI SELF VACUUM CLEANERS

01	AS1 ASPIRATORE SELF SINGOLO · SINGLE SELF VACUUM CLEANER	009
02	AS1-E ASPIRATORE SELF CON RICARICA AUTO ELETTRICA INTEGRATA SELF VACUUM CLEANER WITH INTEGRATED ELECTRIC CAR CHARGER	013
03	AS2 ASPIRATORE SELF DOPPIO · DOUBLE SELF VACUUM CLEANER	017
04	AC1 - AC1 AIR - AC1 AIR PLUS ASPIRATORE SELF SINGOLO · SINGLE SELF VACUUM CLEANER	021
05	AC2 - AC2 AIR - AC2 AIR PLUS ASPIRATORE SELF DOPPIO · DOUBLE SELF VACUUM CLEANER	027
06	AF2 - AF2 AIR - AF2 AIR PLUS ASPIRATORE SELF DOPPIO · DOUBLE SELF VACUUM CLEANER	033
07	AL1 ASPIRATORE SELF SINGOLO · SINGLE SELF VACUUM CLEANER	039
08	AL2 ASPIRATORE SELF DOPPIO · DOUBLE SELF VACUUM CLEANER	043



L'**ACCIAIO INOX** che utilizziamo per le nostre macchine è del tipo AISI 304 quindi a basso contenuto di carbonio.

I principali vantaggi di questo materiale per le nostre applicazioni sono :

- Elevata resistenza alle intemperie e corrosione
- Facilità di ripulitura e ottimo coefficiente igienico

*The **STAINLESS STEEL** used in the construction of our machines is of the type AISI 304 with low carbon content.*

The main advantages of this material for our applications are:

- High level of resistance to extreme weather and corrosion
- Ease of cleaning and maintenance and excellent hygiene properties



La **TURBINA** garantisce una elevata affidabilità e durata nel tempo oltrechè elevata silenziosità di funzionamento, assenza di vibrazioni e non ultimo assenza di manutenzione.

*The **TURBINE** guarantees a high level of reliability and durability over time as well as low-noise functioning, lack of vibrations and last but not least is completely maintenance-free.*



IL **MOTORE BISTADIO con RAFFREDDAMENTO BYPASS** aspira ed espelle l'aria in due tempi creando un "maggiore vuoto" e quindi un'aspirazione più potente.

*The **TWO STAGES MOTOR with BYPASS COOLING** sucks and expels the air in two times creating a "greater vacuum" and therefore a more powerful suction.*

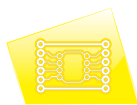

SCHEDA ELETTRONICA, dotata di temporizzatore elettronico, svolge una o più azioni a intervalli di tempo prefissati, facilmente regolabile secondo le esigenze del cliente.

*The **ELECTRONIC CIRCUIT BOARD**, supplied with an electronic timer, manages one or more functions at prefixed intervals, and is easily adjustable according to the client's needs.*



La **GETTONIERA ELETTRONICA**, offerta di serie, combina una straordinaria selettività ad un'estrema versatilità di programmazione.

*The **ELECTRONIC TOKEN AND COIN-OP** mechanism, supplied as standard equipment, combines extraordinary versatility with extreme programming flexibility.*



Nelle nostre macchine utilizziamo esclusivamente **TUBI, BOCCHETTE E RACCORDI IN PLASTICA** di tipo universale quindi di facile reperibilità nel mercato del ricambio.

*In the construction of our machines, we use universal plastic **TUBES, NOZZLES AND JOINTS**, easily available in the spare parts supply market.*



Il nostro sistema elettromeccanico di **PULIZIA AUTOMATICA**

DEL FILTRO dopo ogni ciclo di aspirazione, facilita l'eliminazione della micro-polvere dal filtro a cartuccia, mantenendo quindi una migliore efficienza di aspirazione nel tempo nonché ridotta manutenzione.

*Our electromechanical **AUTOMATIC FILTER CLEANING** mechanism, cleans the filter after every vacuum cycle thereby facilitating the elimination of fine dust from the cartridge filter, and maintaining a high vacuum efficiency and reducing maintenance at the same time.*



IL **MODULO DI RICARICA** eroga corrente alternata mediante presa standard tipo 2.

*The **RECHARGE MODULE** supplies AC through a standard type 2 socket.*

	A51	A51-E	A52	ACT	ACT AIR	ACT AIR PLUS	AC2	AC2 AIR	AC2 AIR PLUS	AF2	AF2 AIR	AF2 AIR PLUS	AL1	AL2
INOX 304	✓	✓	✓	✓	✓	✓	✓	✓	✓	✓	✓	✓	✓	✓
TURBINA	✓	✓	✓	✓	✓	✓	✓	✓	✓	✓	✓	✓		
MOTORE BISTADIO													✓	✓
SCHEDA ELETTRONICA	✓	✓	✓	✓	✓	✓	✓	✓	✓	✓	✓	✓	✓	✓
GETTONIERA ELETTRONICA	✓	✓	✓	✓	✓	✓	✓	✓	✓	✓	✓	✓	✓	✓
TUBI, BOCCHETTE E RACCORDI IN PLASTICA	✓	✓	✓	✓	✓	✓	✓	✓	✓	✓	✓	✓	✓	✓
PULIZIA AUTOMATICA	✓	✓	✓	✓	✓	✓	✓	✓	✓	✓	✓	✓		
MODULO DI RICARICA		✓												

INOX
304

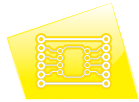

AS1

ASPIRATORE SELF SINGOLO / SINGLE SELF VACUUM CLEANER

- CHIUSURA A DUE PUNTI ANTIVANDALO
- ACCESSO SEPARATO AL BIDONE PER LA MANUTENZIONE ORDINARIA
- CONTENITORE GETTONI LUCCHETTABILE
- TEMPO CICLO PROGRAMMABILE
- AVVIAMENTO MANUALE A RICHIESTA
- CALOTTA IN ABS RESISTENTE AI RAGGI UV
- INNOVATIVO SISTEMA DI RAFFREDDAMENTO DELLA TURBINA
- QUADRO ELETTRICO E GETTONIERA ELETTRONICA INTEGRATI E DI FACILE ACCESSO
- VANDAL-PROOF DOORS AND LOCKS
- SEPARATE ACCESS TO CONTAINER FOR ORDINARY MAINTENANCE
- LOCKABLE TOKEN/COIN COMPARTMENT
- PROGRAMMABLE CYCLE TIME
- MANUAL START ON DEMAND
- ABS COVER, RESISTANT TO UV RAYS
- REVOLUTIONARY INTERNAL COOLING SYSTEM
- EASY ACCESS INTEGRATED ELECTRONIC CONTROL BOARD



ACCESSORI IN DOTAZIONE / SUPPLIED ACCESSORIES

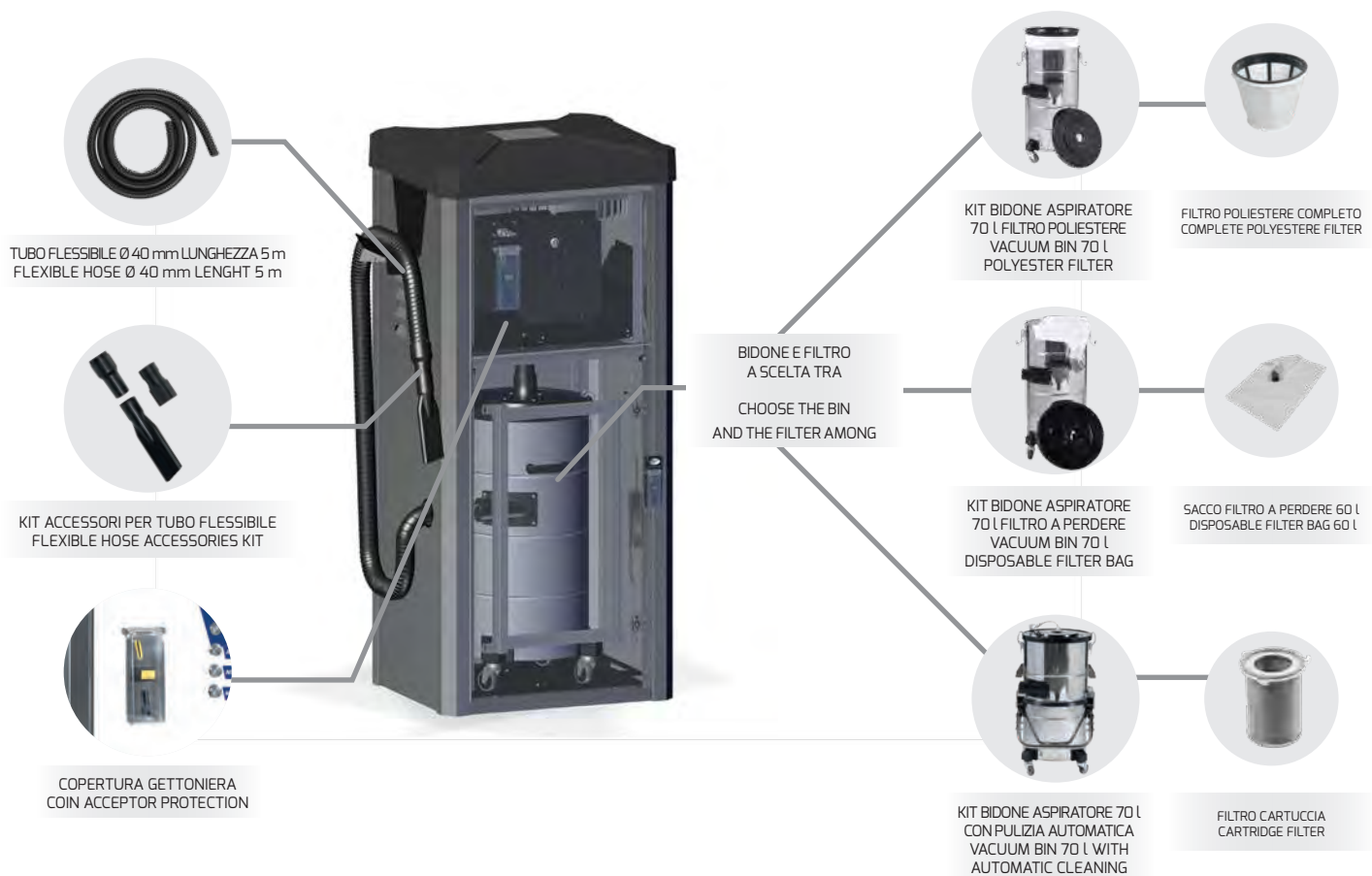

ACCESSORI A RICHIESTA / ACCESSORIES ON DEMAND



CARATTERISTICHE TECNICHE / TECHNICAL FEATURES

Codice Part No.	Potenza Power	Tensione Voltage	Portata d'Aria Air flow	Alimentazione Power Supply	Peso Totale Total Weight	Filtro Filter
3010110005	2,2 kW	230 V - 50 Hz	320 m ³ /h	230 V - 50 Hz	130 kg	a perdere / disposable
3010110006	2,2 kW	230 V - 50 Hz	320 m ³ /h	230 V - 50 Hz	130 kg	poliestere / polyester
3010210003	2,2 kW	230 V - 50 Hz	320 m ³ /h	230 V - 50 Hz	130 kg	automatico / automatic
3010120005	2,2 kW	400 V - 50 Hz	320 m ³ /h	400 V - 50 Hz 5 POLI R-S-T+N	130 kg	a perdere / disposable
3010120006	2,2 kW	400 V - 50 Hz	320 m ³ /h	400 V - 50 Hz 5 POLI R-S-T+N	130 kg	poliestere / polyester
3010220003	2,2 kW	400 V - 50 Hz	320 m ³ /h	400 V - 50 Hz 5 POLI R-S-T+N	130 kg	automatico / automatic
3010140005	3 kW	400 V - 50 Hz	370 m ³ /h	400 V - 50 Hz 5 POLI R-S-T+N	140 kg	a perdere / disposable
3010140006	3 kW	400 V - 50 Hz	370 m ³ /h	400 V - 50 Hz 5 POLI R-S-T+N	140 kg	poliestere / polyester
3010240003	3 kW	400 V - 50 Hz	370 m ³ /h	400 V - 50 Hz 5 POLI R-S-T+N	140 kg	automatico / automatic

ACCESSORI IN DOTAZIONE / SUPPLIED ACCESSORIES

Codice Part No.	Descrizione Description
0964550011	TUBO FLESSIBILE Ø 40 mm LUNGHEZZA 5 m FLEXIBLE HOSE Ø 40 mm LENGHT 5 m
0090611001	KIT ACCESSORI PER TUBO FLESSIBILE FLEXIBLE HOSE ACCESSORIES KIT
0075611017*	KIT BIDONE ASPIRATORE 70 L FILTRO POLIESTERE VACUUM BIN 70 L POLYESTER FILTER
0330211002*	FILTRO POLIESTERE COMPLETO COMPLETE POLYESTER FILTER
0075611016*	KIT BIDONE ASPIRATORE 70 L FILTRO A PERDERE VACUUM BIN 70 L DISPOSABLE FILTER BAG
0800020001*	SACCO FILTRO A PERDERE 60 L DISPOSABLE FILTER BAG 60 L
0075611018*	KIT BIDONE ASPIRATORE 70 L CON PULIZIA AUTOMATICA VACUUM BIN 70 L WITH AUTOMATIC CLEANING
0330020006*	FILTRO CARTUCCIA CARTRIDGE FILTER
0235020005	COPERTURA GETTONIERA COIN ACCEPTOR PROTECTION

* A SECONDA DEL CODICE MACCHINA SCELTO
* DEPENDING ON THE SELECTED MACHINE CODE

** NECESSITA DI COLLEGAMENTO A RETE PNEUMATICA
** REQUIRES A PNEUMATIC NETWORK CONNECTION

ACCESSORI A RICHIESTA / ACCESSORIES ON DEMAND

Codice Part No.	Descrizione Description
0445611009	KIT NEBULIZZATORE SPRAY KIT
0445611010**	KIT ARIA COMPRESSA COMPRESSED AIR KIT
0445611008	KIT NEROGOMME TIRE BLACKENING KIT
0445611024	KIT SOFFIAGGIO ARIA AIR BLOWING KIT
0495022001	KIT EUROKEY NEXT EUROKEY NEXT KIT
0705610003	KIT ISOLAMENTO ACUSTICO SOUNDPROOFING KIT
0102611004	BRACCIO A MOLLA VERTICALE INOX S.STEEL VERTICAL BOOM
0445611057	KIT ILLUMINAZIONE LED LED LIGHT KIT
--	ETICHETTA (vedere pag. 167) LABEL (see on pg. 167)
0445611050	DISPLAY

DIMENSIONI
DIMENSIONSIMBALLO (PALLET LEGNO + PLURIBALL)
PACKAGING (WOOD PALLET + PLURIBALL)SCHEMA DI FISSAGGIO BASAMENTO
INSTALLATION SCHEME

A (mm)	B (mm)	C (mm)	X (mm)	Y (mm)	Z (mm)	D (mm)	E (mm)	F (mm)	G (mm)
592	714	1570	900	1700	800	692.5	562	570.5	440

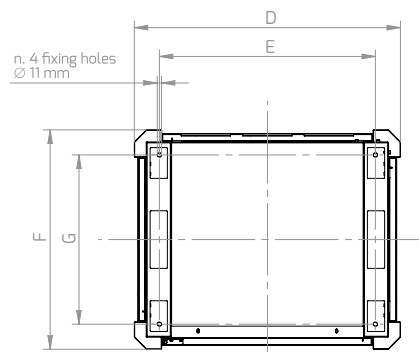
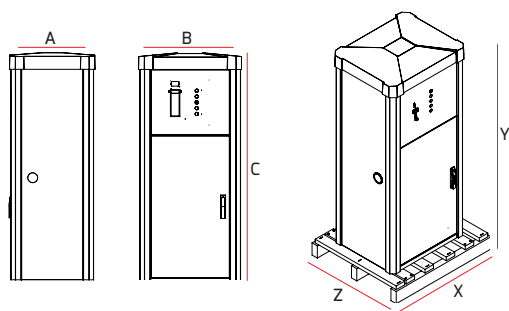

INOX
304



AS1-E

ASPIRATORE SELF CON RICARICA AUTO ELETTRICA INTEGRATA
SELF VACUUM CLEANER WITH INTEGRATED ELECTRIC CAR CHARGER

NEW

MODULO DI ASPIRAZIONE/ VACUUM CLEANER MODULE

- ▲ TURBINA CON POTENZA DA 2,2 KW (TRIFASE) A 3 KW (TRIFASE) CON PORTATA D'ARIA DA 320 M³/H A 370 M³/H E DEPRESSIONE DA 2300 MM/H2O A 3300 MM/H2O
- ▲ TURBINE WITH POWER FROM 2.2 KW (THREE-PHASE) TO 3 KW (THREE-PHASE) WITH AIR FLOW FROM 320 M³/H TO 370 M³/H AND DEPRESSION FROM 2300 MM / H2O TO 3300 MM / H2O.
- ▲ BIDONE IN ACCIAIO INOX CON CAPACITÀ 70 L CON POSSIBILITÀ DI SCELTA TRA FILTRO A PERDERE, FILTRO IN POLIESTERE O FILTRO A CARTUCCIA AUTOPULENTE
- ▲ STAINLESS STEEL BIN WITH 70 L CAPACITY WITH THE POSSIBILITY OF CHOOSING AMONG A DISPOSABLE FILTER, A POLYESTER FILTER OR A SELF-CLEANING CARTRIDGE FILTER
- ▲ GETTONIERA ELETTRONICA E POSSIBILITÀ DI LETTORE CARD E/O KEY
- ▲ ELECTRONIC COIN ACCEPTOR AND POSSIBILITY OF ADDING A CARD AND /OR KEY READER
- ▲ DISPLAY OPZIONALE PER VISUALIZZAZIONE CREDITO INSERITO/ RESIDUO E TEMPO DI LAVORO RESIDUO
- ▲ OPTIONAL DISPLAY FOR CREDIT / RESIDUAL CREDIT AND REMAINING WORK TIME CHECKING

MODULO DI RICARICA AC*/ AC RECHARGE MODULE*

- ▲ PRESA STANDARD TIPO 2
- ▲ STANDARD "TYPE 2" SOCKET
- ▲ EROGAZIONE DI CORRENTE ALTERNATA
- ▲ SUPPLY OF AC
- ▲ FINE CARICA CON PULSANTE DI SBLOCCO SPINA
- ▲ END OF CHARGE WITH PLUG RELEASE BUTTON
- ▲ MODELLI INSTALLABILI: 3,7KW 16A 230VAC / 7,4KW 32A 230VAC / 11KW 16A 400VAC/22KW 32A 400VAC
- ▲ INSTALLABLE VERSIONS: 3.7KW 16A 230VAC / 7.4KW 32A 230VAC / 11KW 16A 400VAC/22KW 32A 400VAC
- ▲ CENTRALINA CONFORME ALLA RICARICA "MODO 3" DELLA NORMATIVA INTERNAZIONALE IEC/EN 61851-1
- ▲ CONTROL UNIT COMPLIANT WITH THE "MODE 3" RECHARGE OF THE INTERNATIONAL STANDARD IEC / EN 61851-1

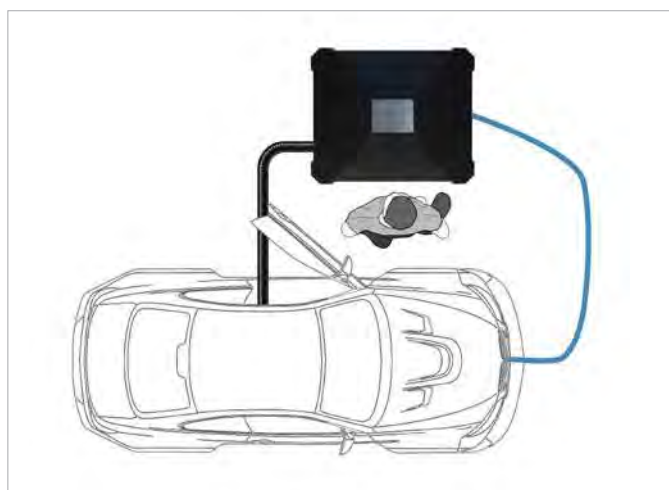

ACCESSORI IN DOTAZIONE / SUPPLIED ACCESSORIES

**TUBO FLESSIBILE Ø 40 mm LUNGHEZZA 5 m
FLEXIBLE HOSE Ø 40 mm LENGHT 5 m**

**COPERTURA GETTONIERA
COIN ACCEPTOR PROTECTION**

**KIT ACCESSORI PER TUBO FLESSIBILE
FLEXIBLE HOSE ACCESSORIES KIT**

**BIDONE E FILTRO
A SCELTA TRA
CHOOSE THE BIN
AND THE FILTER AMONG**

- KIT BIDONE ASPIRATORE
70 L FILTRO POLIESTERE
VACUUM BIN 70 L
POLYESTER FILTER**
- FILTRO POLIESTERE COMPLETO
COMPLETE POLYESTER FILTER**
- KIT BIDONE ASPIRATORE
70 L FILTRO A PERDERE
VACUUM BIN 70 L
DISPOSABLE FILTER BAG**
- SACCO FILTRO A PERDERE 60 L
DISPOSABLE FILTER BAG 60 L**
- KIT BIDONE ASPIRATORE 70 L
CON PULIZIA AUTOMATICA
VACUUM BIN 70 L WITH
AUTOMATIC CLEANING**
- FILTRO CARTUCCIA
CARTRIDGE FILTER**

ACCESSORI A RICHIESTA / ACCESSORIES ON DEMAND

**KIT EUROKEY NEXT
EUROKEY NEXT KIT**

**KIT ILLUMINAZIONE LED
LED LIGHT KIT**

**CASSETTO GETTONIERA LUCCHETTABILE
LOCKABLE COIN COMPARTMENT**

**KIT ISOLAMENTO ACUSTICO
SOUNDPROOFING KIT**

**BRACCIO A MOLLA VERTICALE INOX
S.STEEL VERTICAL BOOM**

DISPLAY

**ETICHETTA (vedere pag. 167)
LABEL (see on pg. 167)**

CARATTERISTICHE TECNICHE / TECHNICAL FEATURES

Codice Part No.	Potenza Power	Tensione Voltage	Portata d'Aria Air flow	Alimentazione Power Supply	Modulo di Ricarica Charging Module	Peso Totale Total Weight	Filtro Filter
3011920001	2,2 kW	400 V - 50 Hz	320 m ³ /h	400 V - 50 Hz 5 POLI R-S-T+N	22 kW - 32A	135 kg	a perdere / disposable
3011920002	2,2 kW	400 V - 50 Hz	320 m ³ /h	400 V - 50 Hz 5 POLI R-S-T+N	22 kW - 32A	135 kg	poliestere / polyester
3011920003	2,2 kW	400 V - 50 Hz	320 m ³ /h	400 V - 50 Hz 5 POLI R-S-T+N	22 kW - 32A	135 kg	automatico / automatic
3011920004	2,2 kW	400 V - 50 Hz	320 m ³ /h	400 V - 50 Hz 5 POLI R-S-T+N	11 kW - 16A	135 kg	a perdere / disposable
3011920005	2,2 kW	400 V - 50 Hz	320 m ³ /h	400 V - 50 Hz 5 POLI R-S-T+N	11 kW - 16A	135 kg	poliestere / polyester
3011920006	2,2 kW	400 V - 50 Hz	320 m ³ /h	400 V - 50 Hz 5 POLI R-S-T+N	11 kW - 16A	135 kg	automatico / automatic
3011940001	3 kW	400 V - 50 Hz	370 m ³ /h	400 V - 50 Hz 5 POLI R-S-T+N	22 kW - 32A	145 kg	a perdere / disposable
3011940002	3 kW	400 V - 50 Hz	370 m ³ /h	400 V - 50 Hz 5 POLI R-S-T+N	22 kW - 32A	145 kg	poliestere / polyester
3011940003	3 kW	400 V - 50 Hz	370 m ³ /h	400 V - 50 Hz 5 POLI R-S-T+N	22 kW - 32A	145 kg	automatico / automatic
3011940004	3 kW	400 V - 50 Hz	370 m ³ /h	400 V - 50 Hz 5 POLI R-S-T+N	11 kW - 16A	145 kg	a perdere / disposable
3011940005	3 kW	400 V - 50 Hz	370 m ³ /h	400 V - 50 Hz 5 POLI R-S-T+N	11 kW - 16A	145 kg	poliestere / polyester
3011940006	3 kW	400 V - 50 Hz	370 m ³ /h	400 V - 50 Hz 5 POLI R-S-T+N	11 kW - 16A	145 kg	automatico / automatic

ACCESSORI IN DOTAZIONE / SUPPLIED ACCESSORIES

ACCESSORI A RICHIESTA / ACCESSORIES ON DEMAND

Codice Part No.	Descrizione Description	Codice Part No.	Descrizione Description
0964550011	TUBO FLESSIBILE Ø 40 mm LUNGHEZZA 5 m FLEXIBLE HOSE Ø 40 mm LENGHT 5 m	0495022001	KIT EUROKEY NEXT EUROKEY NEXT KIT
0090611001	KIT ACCESSORI PER TUBO FLESSIBILE FLEXIBLE HOSE ACCESSORIES KIT	0705610003	KIT ISOLAMENTO ACUSTICO SOUNDPROOFING KIT
0075611017*	KIT BIDONE ASPIRATORE 70 L FILTRO POLIESTERE VACUUM BIN 70 L POLYESTER FILTER	0102611004	BRACCIO A MOLLA VERTICALE INOX S.STEEL VERTICAL BOOM
0330211002*	FILTRO POLIESTERE COMPLETO COMPLETE POLYESTERE FILTER	0445611057	KIT ILLUMINAZIONE LED LED LIGHT KIT
0075611016*	KIT BIDONE ASPIRATORE 70 L FILTRO A PERDERE VACUUM BIN 70 L DISPOSABLE FILTER BAG	--	ETICHETTA (vedere pag. 167) LABEL (see on pg. 167)
0800020001*	SACCO FILTRO A PERDERE 60 L DISPOSABLE FILTER BAG 60 L	0445611050	DISPLAY
0075611018*	KIT BIDONE ASPIRATORE 70 L CON PULIZIA AUTOMATICA VACUUM BIN 70 L WITH AUTOMATIC CLEANING		
0330020006*	FILTRO CARTUCCIA CARTRIDGE FILTER		
0235020005	COPERTURA GETTONIERA COIN ACCEPTOR PROTECTION		

* A SECONDA DEL CODICE MACCHINA SCELTO
* DEPENDING ON THE SELECTED MACHINE CODE

DIMENSIONI
DIMENSIONS

IMBALLO (PALLET LEGNO + PLURIBALL)
PACKAGING (WOOD PALLET + PLURIBALL)

SCHEMA DI FISSAGGIO BASAMENTO
INSTALLATION SCHEME

A (mm)	B (mm)	C (mm)	X (mm)	Y (mm)	Z (mm)	D (mm)	E (mm)	F (mm)	G (mm)
592	714	1570	900	1700	800	692.5	562	570.5	440

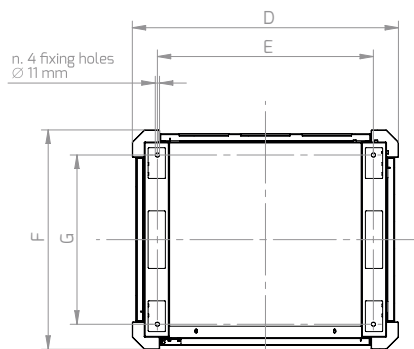
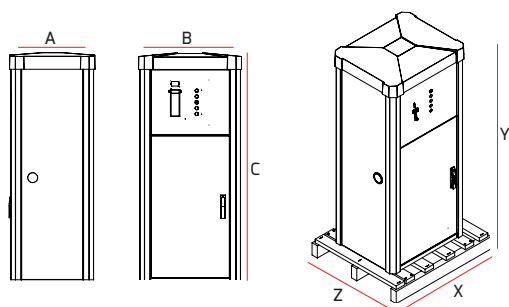



AS2

ASPIRATORE SELF DOPPIO / DOUBLE SELF VACUUM CLEANER

- ▼ PANNELLO COMANDI SUL LATO LUNGO
- ▼ CHIUSURA A DUE PUNTI ANTIVANDALO
- ▼ ACCESSO SEPARATO AL BIDONE PER LA MANUTENZIONE ORDINARIA
- ▼ CONTENITORE GETTONI LUCCHETTABILE
- ▼ TEMPO CICLO PROGRAMMABILE
- ▼ AVVIAMENTO MANUALE A RICHIESTA
- ▼ CALOTTA IN ABS RESISTENTE AI RAGGI UV
- ▼ INNOVATIVO SISTEMA DI RAFFREDDAMENTO DELLA TURBINA
- ▼ QUADRO ELETTRICO E GETTONIERA ELETTRONICA INTEGRATI E DI FACILE ACCESSO
- ▼ CONTROL PANEL ON THE LONG SIDE
- ▼ VANDAL-PROOF DOORS AND LOCKS
- ▼ SEPARATE ACCESS TO CONTAINER FOR ORDINARY MAINTENANCE
- ▼ LOCKABLE TOKEN/COIN COMPARTMENT
- ▼ PROGRAMMABLE CYCLE TIME
- ▼ MANUAL START ON DEMAND
- ▼ ABS COVER, RESISTANT TO UV RAYS
- ▼ REVOLUTIONARY INTERNAL COOLING SYSTEM
- ▼ EASY ACCESS INTEGRATED ELECTRONIC CONTROL BOARD

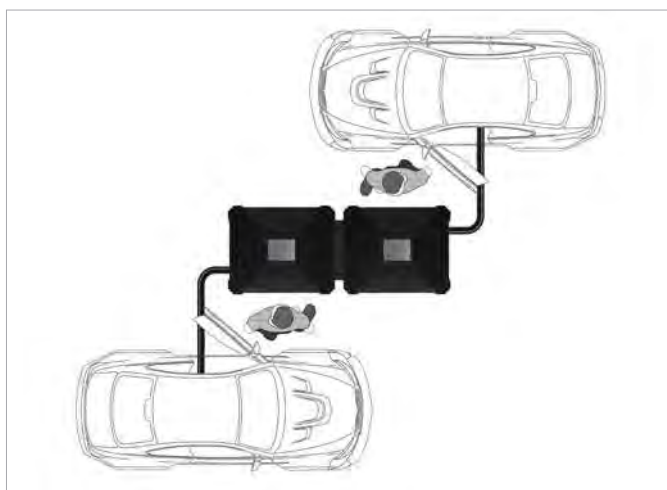

ACCESSORI IN DOTAZIONE / SUPPLIED ACCESSORIES

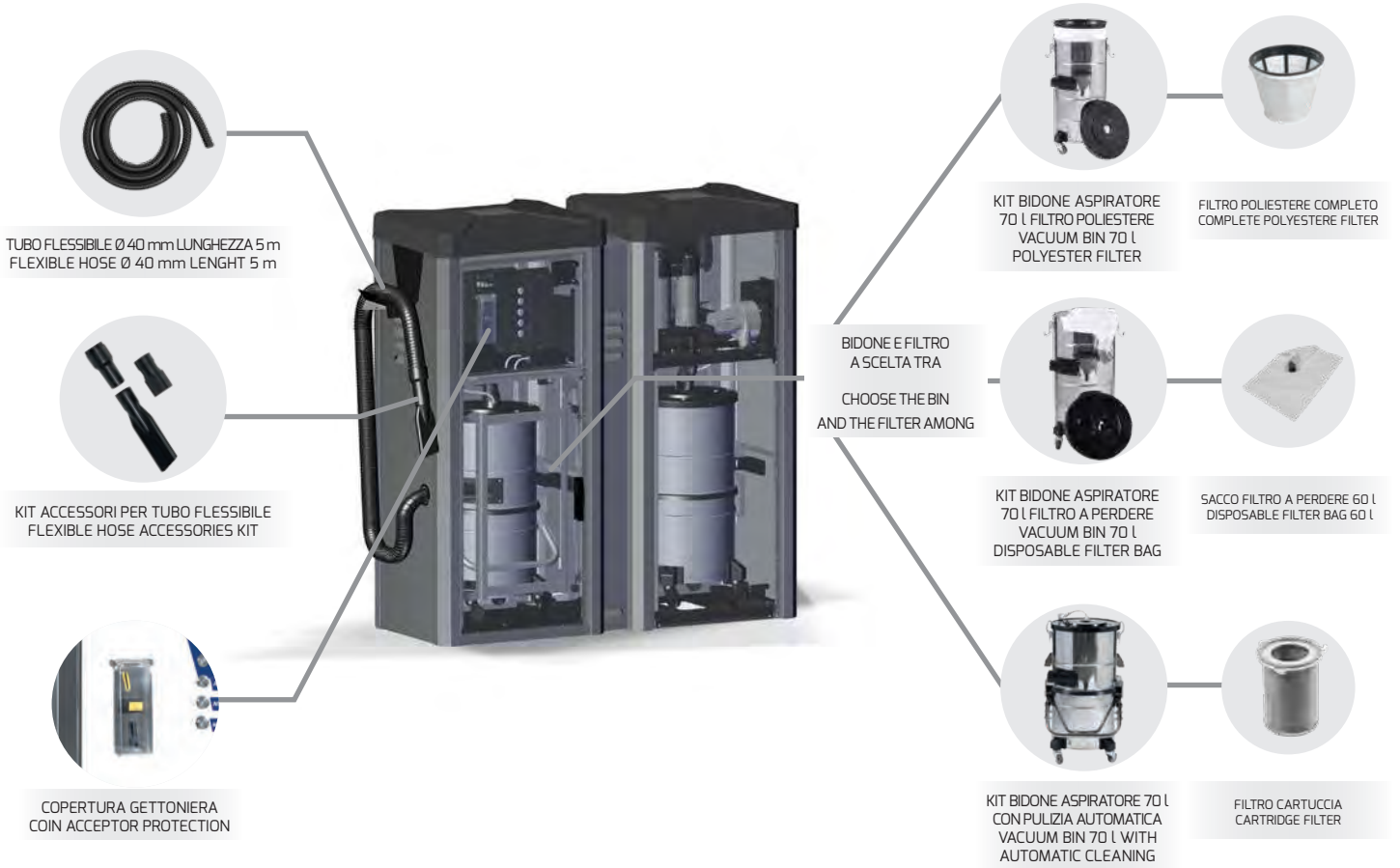

ACCESSORI A RICHIESTA / ACCESSORIES ON DEMAND

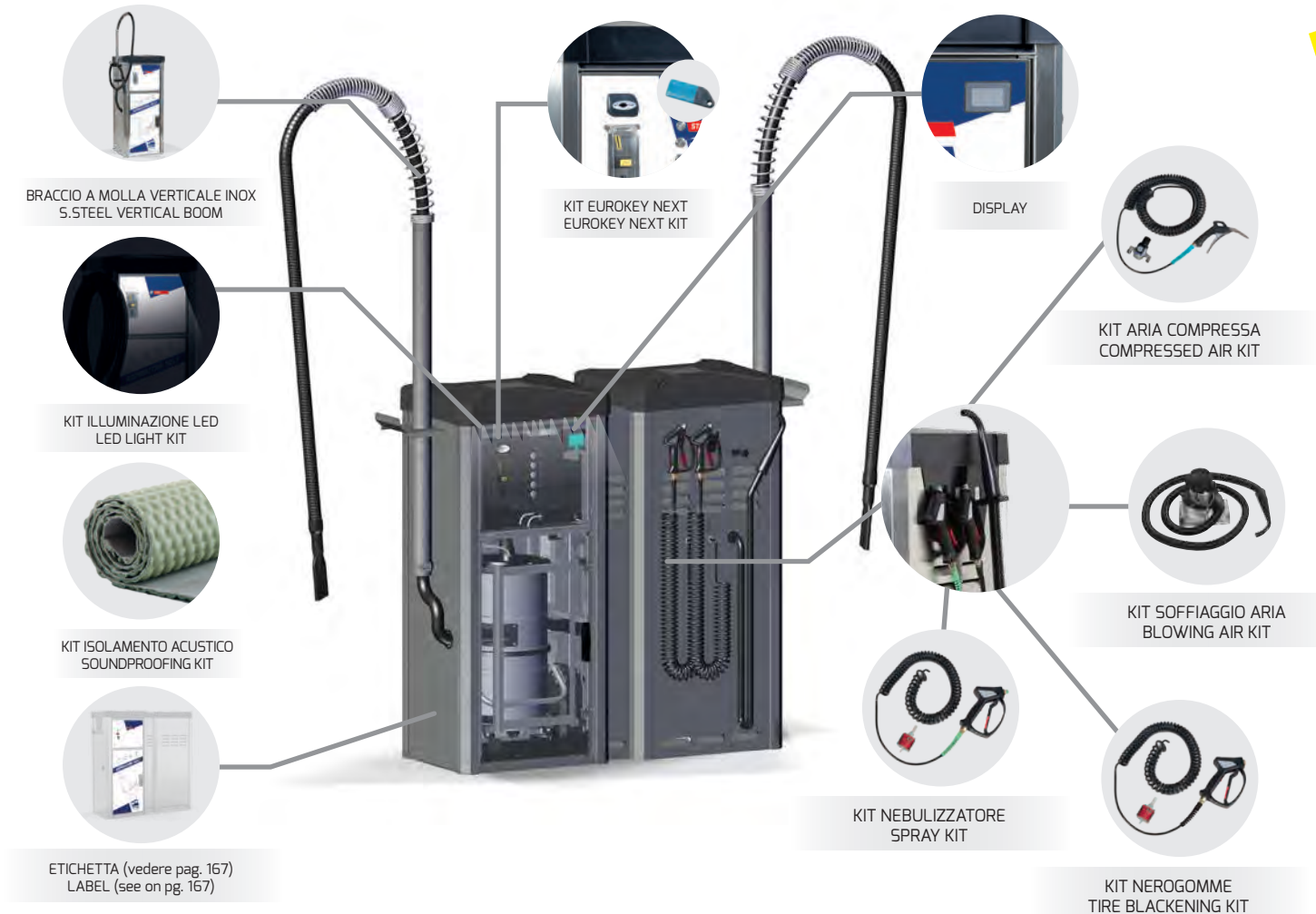

CARATTERISTICHE TECNICHE / TECHNICAL FEATURES

Codice Part No.	Potenza Power	Tensione Voltage	Portata d'Aria Air flow	Alimentazione Power Supply	Peso Totale Total Weight	Filtro Filter
3010330001	2 x 2,2 kW	230 V - 50 Hz	320 m ³ /h	230 V - 50 Hz	250 kg	a perdere / disposable
3010330002	2 x 2,2 kW	230 V - 50 Hz	320 m ³ /h	230 V - 50 Hz	250 kg	poliestere / polyester
3010410001	2 x 2,2 kW	230 V - 50 Hz	320 m ³ /h	230 V - 50 Hz	250 kg	automatico / automatic
3010320001	2 x 2,2 kW	400 V - 50 Hz	320 m ³ /h	400 V - 50 Hz 5 POLI R-S-T+N	250 kg	a perdere / disposable
3010320002	2 x 2,2 kW	400 V - 50 Hz	320 m ³ /h	400 V - 50 Hz 5 POLI R-S-T+N	250 kg	poliestere / polyester
3010420001	2 x 2,2 kW	400 V - 50 Hz	320 m ³ /h	400 V - 50 Hz 5 POLI R-S-T+N	250 kg	automatico / automatic
3010340001	2 x 3 kW	400 V - 50 Hz	370 m ³ /h	400 V - 50 Hz 5 POLI R-S-T+N	270 kg	a perdere / disposable
3010340002	2 x 3 kW	400 V - 50 Hz	370 m ³ /h	400 V - 50 Hz 5 POLI R-S-T+N	270 kg	poliestere / polyester
3010440001	2 x 3 kW	400 V - 50 Hz	370 m ³ /h	400 V - 50 Hz 5 POLI R-S-T+N	270 kg	automatico / automatic

ACCESSORI IN DOTAZIONE / SUPPLIED ACCESSORIES

Codice (1 pz.) Part No. (1 piece)	Descrizione Description	Quantità Quantity
0964550011	TUBO FLESSIBILE Ø 40 mm LUNGHEZZA 5 m FLEXIBLE HOSE Ø 40 mm LENGHT 5 m	2
0090611001	KIT ACCESSORI PER TUBO FLESSIBILE FLEXIBLE HOSE ACCESSORIES KIT	2
0075611017*	KIT BIDONE ASPIRATORE 70 L FILTRO POLIESTERE VACUUM BIN 70 L POLYESTER FILTER	2
0330211002*	FILTRO POLIESTERE COMPLETO COMPLETE POLYESTERE FILTER	2
0075611016*	KIT BIDONE ASPIRATORE 70 L FILTRO A PERDERE VACUUM BIN 70 L DISPOSABLE FILTER BAG	2
0800020001*	SACCO FILTRO A PERDERE 60 L DISPOSABLE FILTER BAG 60 L	2
0075611018*	KIT BIDONE ASPIRATORE 70 L CON PULIZIA AUTOMATICA VACUUM BIN 70 L WITH AUTOMATIC CLEANING	2
0330020006*	FILTRO CARTUCCIA CARTRIDGE FILTER	2
0235020005	COPERTURA GETTONIERA COIN ACCEPTOR PROTECTION	2

* A SECONDA DEL CODICE MACCHINA SCELTO
* DEPENDING ON THE SELECTED MACHINE CODE

** NECESSITA DI COLLEGAMENTO A RETE PNEUMATICA
** REQUIRES A PNEUMATIC NETWORK CONNECTION

ACCESSORI A RICHIESTA / ACCESSORIES ON DEMAND

Codice Part No.	Descrizione Description
0445611009	KIT NEBULIZZATORE SPRAY KIT
0445611010**	KIT ARIA COMPRESSA COMPRESSED AIR KIT
0445611008	KIT NEROGOMME TIRE BLACKENING KIT
0445611024	KIT SOFFIAGGIO ARIA AIR BLOWING KIT
0495022001	KIT EUROKEY NEXT EUROKEY NEXT KIT
0705610003	KIT ISOLAMENTO ACUSTICO SOUNDPROOFING KIT
0102611004	BRACCIO A MOLLA VERTICALE INOX S.STEEL VERTICAL BOOM
0445611057	KIT ILLUMINAZIONE LED LED LIGHT KIT
--	ETICHETTA (vedere pag. 167) LABEL (see on pg. 167)
0445611050	DISPLAY

DIMENSIONI
DIMENSIONSIMBALLO (PALLET LEGNO + PLURIBALL)
PACKAGING (WOOD PALLET + PLURIBALL)SCHEMA DI FISSAGGIO BASAMENTO
INSTALLATION SCHEME

A (mm)	B (mm)	C (mm)	X (mm)	Y (mm)	Z (mm)	D (mm)	E (mm)	F (mm)	G (mm)	H (mm)	I (mm)
592	1526	1570	1755	1700	800	562	250	562	1505	440	570.5

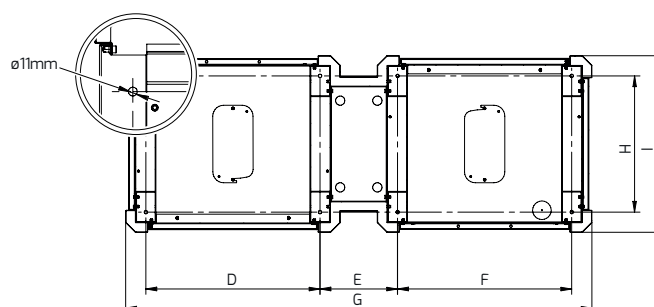
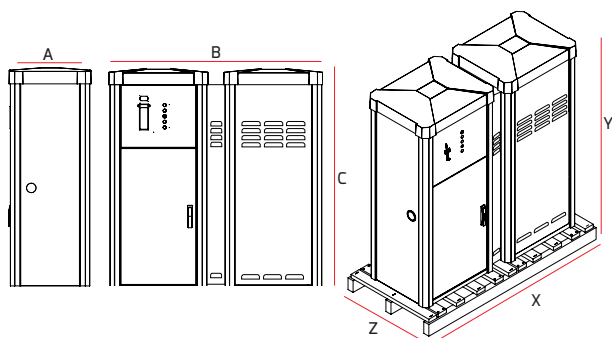

INOX
304

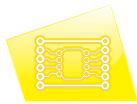







AC1

AC1 AIR

AC1 AIR PLUS

AC1 - AC1 AIR - AC1 AIR PLUS

ASPIRATORE SELF SINGOLO / SINGLE SELF VACUUM CLEANER

- | | |
|--|---|
| <ul style="list-style-type: none"> ▲ CHIUSURA A DUE PUNTI ANTIVANDALO ▲ TEMPO CICLO PROGRAMMABILE ▲ AVVIAMENTO MANUALE A RICHIESTA ▲ CALOTTA IN ABS RESISTENTE AI RAGGI UV ▲ TRE CONFIGURAZIONI DI USCITA DEL TUBO ASPIRATORE
 <div style="display: flex; justify-content: space-around; align-items: center; margin-top: 5px;">  SINISTRA  DESTRA  RETRO </div> ▲ SPORTELLI ANTERIORI E POSTERIORI FACILMENTE RIMOVIBILI PER INTERVENTI DI MANUTENZIONE ▲ NUOVI BIDONI IN ACCIAIO INOX ▲ A RICHIESTA TURBINA 1,5 kW (230V-50Hz/400V - 50Hz) ▲ KIT ARIA COMPRESSA INCLUSO, NECESSITA DI COLLEGAMENTO A RETE PNEUMATICA (ACT1 AIR - ACT1 AIR PLUS) ▲ KIT NEBULIZZATORE INCLUSO (ACT1 AIR PLUS) | <ul style="list-style-type: none"> ▲ VANDAL-PROOF DOORS AND LOCKS ▲ PROGRAMMABLE CYCLE TIME ▲ MANUAL START ON DEMAND ▲ ABS COVER, RESISTANT TO UV RAYS ▲ THREE CONFIGURATIONS FOR VACUUM HOSE OUTLET
 <div style="display: flex; justify-content: space-around; align-items: center; margin-top: 5px;">  LEFT  RIGHT  BACK </div> ▲ FRONT AND REAR COVER PANELS EASY TO REMOVE FOR MAINTENANCE OPERATIONS ▲ NEW STAINLESS STEEL BINS ▲ 1,5 kW TURBINE ON DEMAND (230V-50Hz/400V - 50Hz) ▲ COMPRESSED AIR KIT ALWAYS SUPPLIED, REQUIRES A PNEUMATIC NETWORK CONNECTION (ACT1 AIR - ACT1 AIR PLUS) ▲ SPRAY KIT INCLUDED (ACT1 AIR PLUS) |
|--|---|

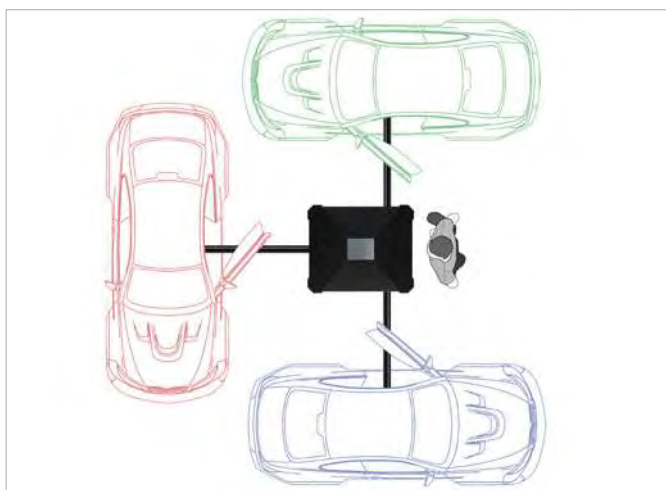

ACCESSORI IN DOTAZIONE / SUPPLIED ACCESSORIES

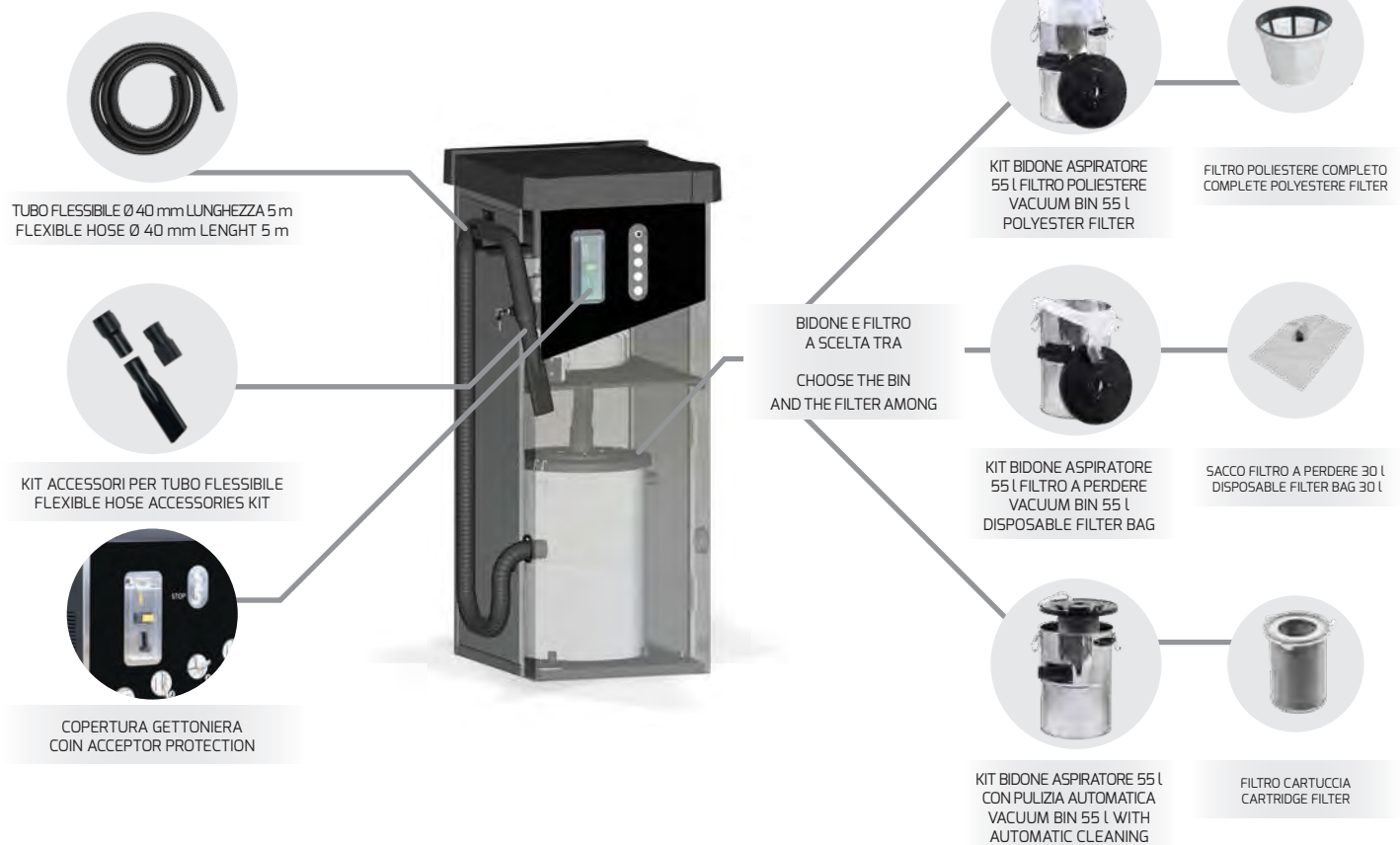

ACCESSORI A RICHIESTA / ACCESSORIES ON DEMAND



ACCESSORI IN DOTAZIONE / SUPPLIED ACCESSORIES



ACCESSORI A RICHIESTA / ACCESSORIES ON DEMAND

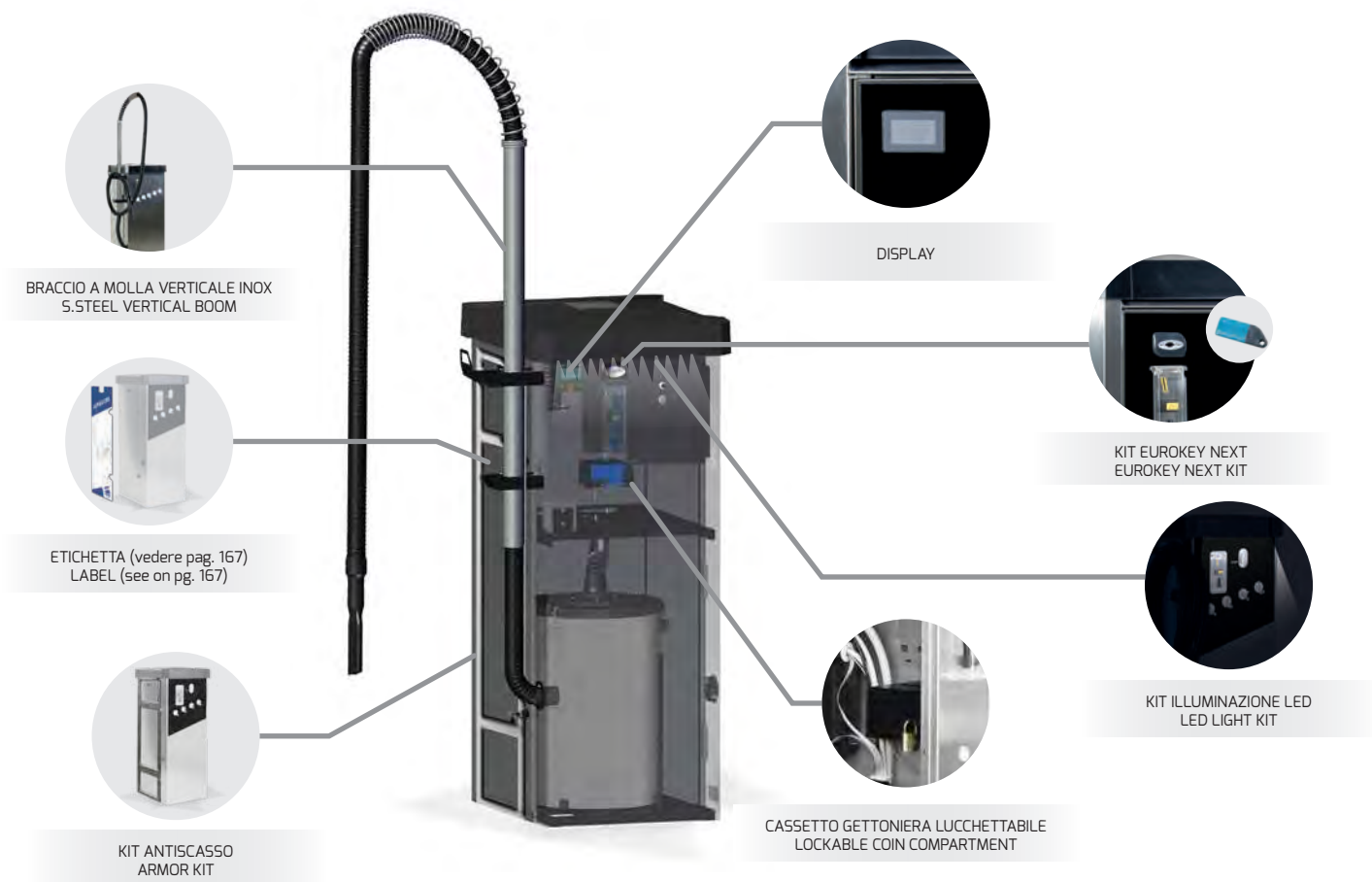

ACCESSORI IN DOTAZIONE / SUPPLIED ACCESSORIES

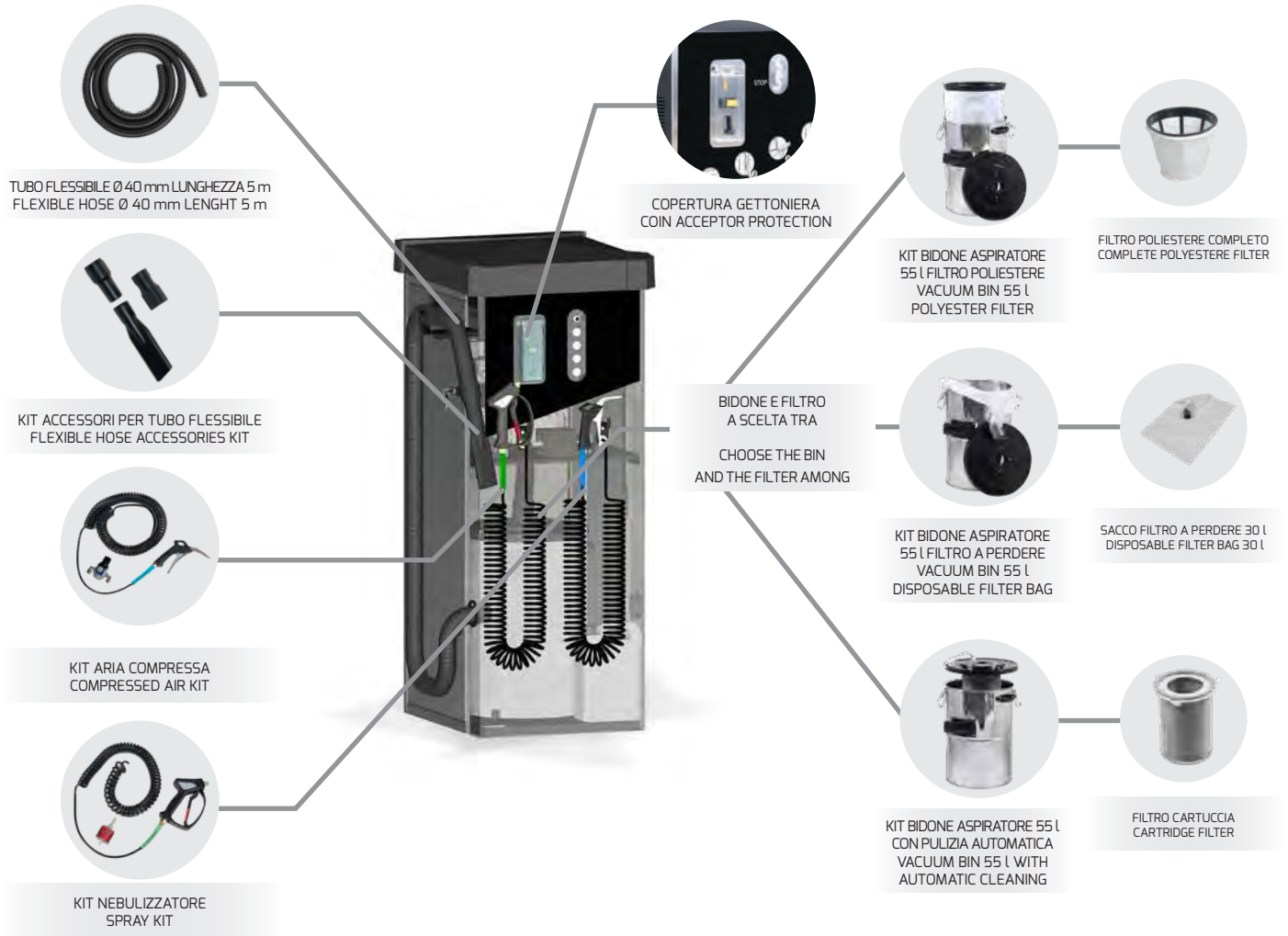

ACCESSORI A RICHIESTA / ACCESSORIES ON DEMAND



CARATTERISTICHE TECNICHE / TECHNICAL FEATURES

Codice Part No.	Modello Model	Potenza Power	Tensione Voltage	Portata d'Aria Air flow	Alimentazione Power Supply	Peso Totale Total Weight	Filtro Filter
3011420001	AC1	2,2 kW	400 V - 50 Hz	260 m ³ /h	400 V - 50 Hz 5 POLI R-5-T+N	80 kg	a perdere / disposable
3011420002	AC1	2,2 kW	400 V - 50 Hz	260 m ³ /h	400 V - 50 Hz 5 POLI R-5-T+N	80 kg	poliestere / polyester
3011520001	AC1	2,2 kW	400 V - 50 Hz	260 m ³ /h	400 V - 50 Hz 5 POLI R-5-T+N	80 kg	automatico / automatic
3011420003	AC1 AIR	2,2 kW	400 V - 50 Hz	260 m ³ /h	400 V - 50 Hz 5 POLI R-5-T+N	81 kg	a perdere / disposable
3011420004	AC1 AIR	2,2 kW	400 V - 50 Hz	260 m ³ /h	400 V - 50 Hz 5 POLI R-5-T+N	81 kg	poliestere / polyester
3011520002	AC1 AIR	2,2 kW	400 V - 50 Hz	260 m ³ /h	400 V - 50 Hz 5 POLI R-5-T+N	81 kg	automatico / automatic
3011420005	AC1 AIR PLUS	2,2 kW	400 V - 50 Hz	260 m ³ /h	400 V - 50 Hz 5 POLI R-5-T+N	82 kg	a perdere / disposable
3011420006	AC1 AIR PLUS	2,2 kW	400 V - 50 Hz	260 m ³ /h	400 V - 50 Hz 5 POLI R-5-T+N	82 kg	poliestere / polyester
3011520003	AC1 AIR PLUS	2,2 kW	400 V - 50 Hz	260 m ³ /h	400 V - 50 Hz 5 POLI R-5-T+N	82 kg	automatico / automatic

ACCESSORI IN DOTAZIONE / SUPPLIED ACCESSORIES

Codice Part No.	Modello Model	Descrizione Description
0964550011	TUTTI ALL	TUBO FLESSIBILE Ø 40 mm LUNGHEZZA 5 m FLEXIBLE HOSE Ø 40 mm LENGHT 5 m
0090611001	TUTTI ALL	KIT ACCESSORI PER TUBO FLESSIBILE FLEXIBLE HOSE ACCESSORIES KIT
0075611019*	TUTTI ALL	KIT BIDONE ASPIRATORE 55 L FILTRO POLIESTERE VACUUM BIN 55 L POLYESTER FILTER
0330211002*	TUTTI ALL	FILTRO POLIESTERE COMPLETO COMPLETE POLYESTER FILTER
0075611021*	TUTTI ALL	KIT BIDONE ASPIRATORE 55 L FILTRO A PERDERE VACUUM BIN 55 L DISPOSABLE FILTER BAG
0800020002*	TUTTI ALL	SACCO FILTRO A PERDERE 30 L DISPOSABLE FILTER BAG 30 L
0075611020*	TUTTI ALL	KIT BIDONE ASPIRATORE 55 L CON PULIZIA AUTOMATICA VACUUM BIN 55 L WITH AUTOMATIC CLEANING
0330020006*	TUTTI ALL	FILTRO CARTUCCIA CARTRIDGE FILTER
0235020005	TUTTI ALL	COPERTURA GETTONIERA COIN ACCEPTOR PROTECTION
0445611030***	ACT1 AIR ACT1 AIR PLUS	KIT ARIA COMPRESSA COMPRESSED AIR KIT
0445611029	ACT1 AIR PLUS	KIT NEBULIZZATORE SPRAY KIT

ACCESSORI A RICHIESTA / ACCESSORIES ON DEMAND

Codice Part No.	Modello Model	Descrizione Description
0495022001	TUTTI ALL	KIT EUROKEY NEXT EUROKEY NEXT KIT
0445611047	TUTTI ALL	KIT ILLUMINAZIONE LED LED LIGHT KIT
0170242011	TUTTI ALL	CASSETTO GETTONIERA LUCCHETTABILE LOCKABLE COIN COMPARTMENT
--	TUTTI ALL	ETICHETTA (vedere pag. 167) LABEL (see on pg. 167)
0102611002	TUTTI ALL	BRACCIO A MOLLA VERTICALE INOX S.STEEL VERTICAL BOOM
0445611048	ACT1 AIR PLUS	KIT ANTIGELO NO FROST KIT
0445611049	ACT1	KIT SOFFIAGGIO ARIA AIR BLOWING KIT
0445611099**	TUTTI ALL	KIT ANTISCASSO ARMOR KIT
0445611050	TUTTI ALL	DISPLAY

** CODICE ESPRESSO RIFERITO A SINGOLO KIT (KIT DA INSTALLARE FRONTE E/O RETRO)
** CODE REFERRED TO A SINGLE KIT (KIT TO INSTALL FRONT AND / OR REAR)

* A SECONDA DEL CODICE MACCHINA SCELTO
* DEPENDING ON THE SELECTED MACHINE CODE

*** NECESSITA DI COLLEGAMENTO A RETE PNEUMATICA
*** REQUIRES A PNEUMATIC NETWORK CONNECTION

DIMENSIONI
DIMENSIONS

IMBALLO (PALLET LEGNO + PLURIBALL)
PACKAGING (WOOD PALLET + PLURIBALL)

SCHEMA DI FISSAGGIO BASAMENTO
INSTALLATION SCHEME

A (mm)	B (mm)	C (mm)	X (mm)	Y (mm)	Z (mm)	D (mm)	E (mm)
592	714	1448	900	1578	800	453	600

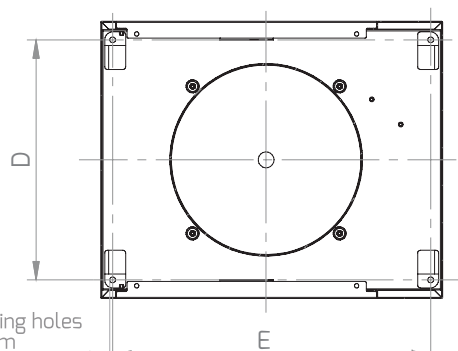
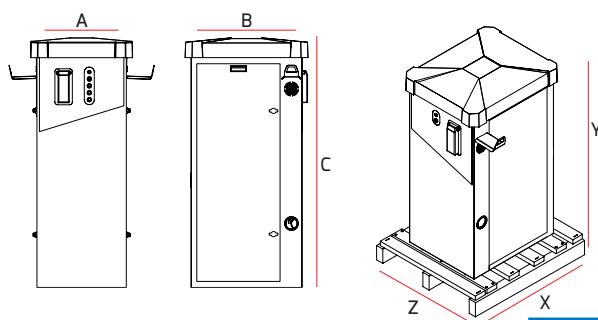

INOX
304

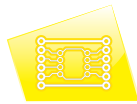



AC2

AC2 AIR

AC2 AIR PLUS

AC2 - AC2 AIR - AC2 AIR PLUS

ASPIRATORE SELF DOPPIO / DOUBLE SELF VACUUM CLEANER

- ▲ PANNELLO COMANDI SUL LATO CORTO
- ▲ CONTROL PANEL ON THE SHORT SIDE
- ▲ CHIUSURA A DUE PUNTI ANTIVANDALO
- ▲ VANDAL-PROOF DOORS AND LOCKS
- ▲ TEMPO CICLO PROGRAMMABILE
- ▲ PROGRAMMABLE CYCLE TIME
- ▲ AVVIAMENTO MANUALE A RICHIESTA
- ▲ MANUAL START ON DEMAND
- ▲ CALOTTA IN ABS RESISTENTE AI RAGGI UV
- ▲ ABS COVER, RESISTANT TO UV RAYS
- ▲ DUE CONFIGURAZIONI DI USCITA DEL TUBO ASPIRATORE
- ▲ TWO CONFIGURATIONS FOR VACUUM HOSE OUTLET
-  SINISTRA
  DESTRA
  LEFT
  RIGHT
- ▲ SPORTELLI ANTERIORI E POSTERIORI FACILMENTE RIMOVIBILI PER INTERVENTI DI MANUTENZIONE
- ▲ FRONT AND REAR COVER PANELS EASY TO REMOVE FOR MAINTENANCE OPERATIONS
- ▲ NUOVI BIDONI IN ACCIAIO INOX
- ▲ NEW STAINLESS STEEL BINS
- ▲ A RICHIESTA TURBINA 2 x 1,5 kW (230V-50Hz/400V - 50Hz)
- ▲ 2 x 1,5 kW TURBINE ON DEMAND (230V-50Hz/400V - 50Hz)
- ▲ KIT ARIA COMPRESSA INCLUSO, NECESSITA DI COLLEGAMENTO A RETE PNEUMATICA (AC2 AIR - AC2 AIR PLUS)
- ▲ COMPRESSED AIR KIT ALWAYS SUPPLIED, REQUIRES A PNEUMATIC NETWORK CONNECTION (AC2 AIR - AC2 AIR PLUS)
- ▲ KIT NEBULIZZATORE INCLUSO (AC2 AIR PLUS)
- ▲ SPRAY KIT INCLUDED (AC2 AIR PLUS)

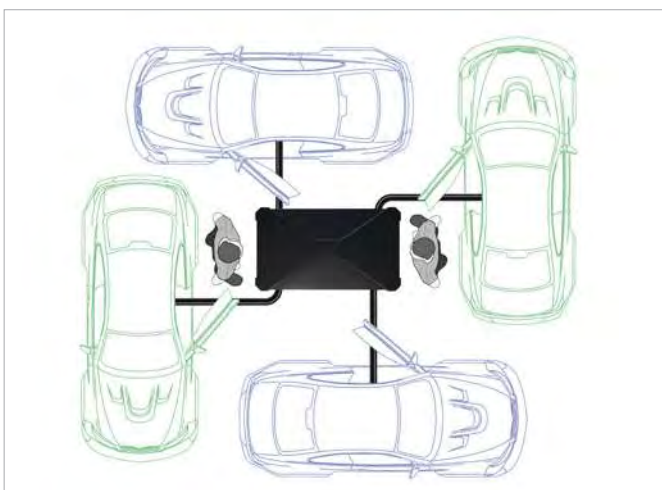

ACCESSORI IN DOTAZIONE / SUPPLIED ACCESSORIES

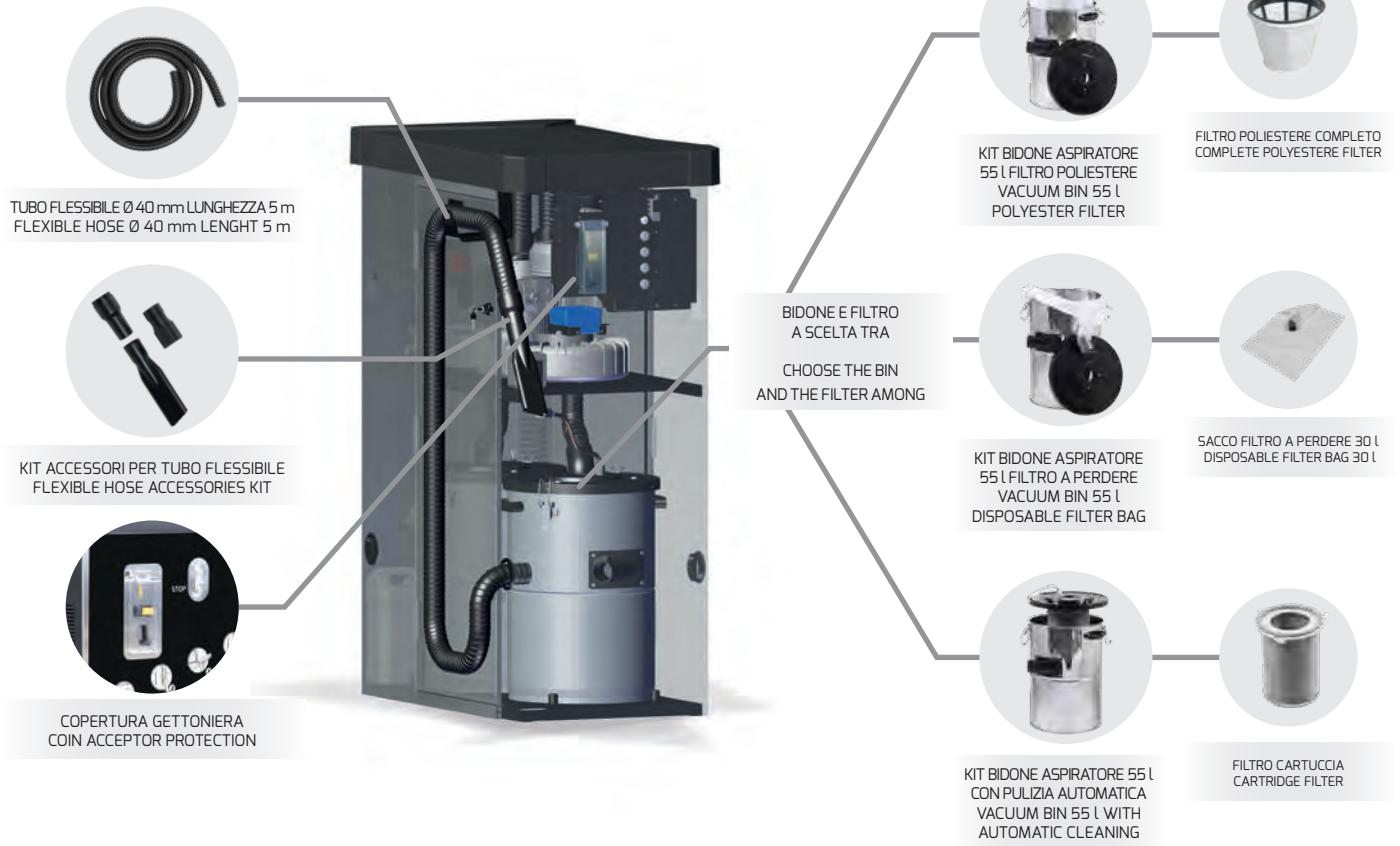

ACCESSORI A RICHIESTA / ACCESSORIES ON DEMAND



ACCESSORI IN DOTAZIONE / SUPPLIED ACCESSORIES

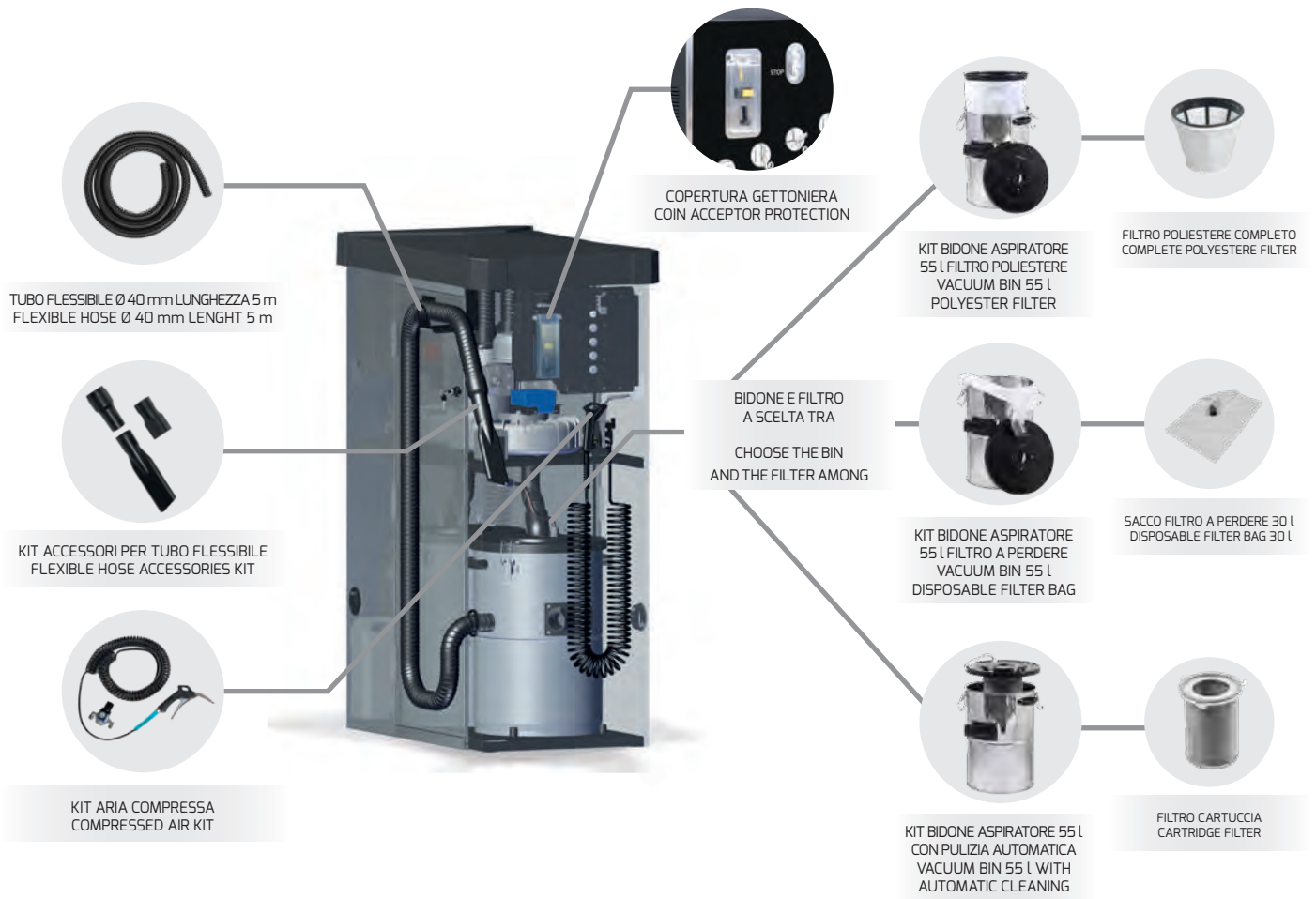

ACCESSORI A RICHIESTA / ACCESSORIES ON DEMAND

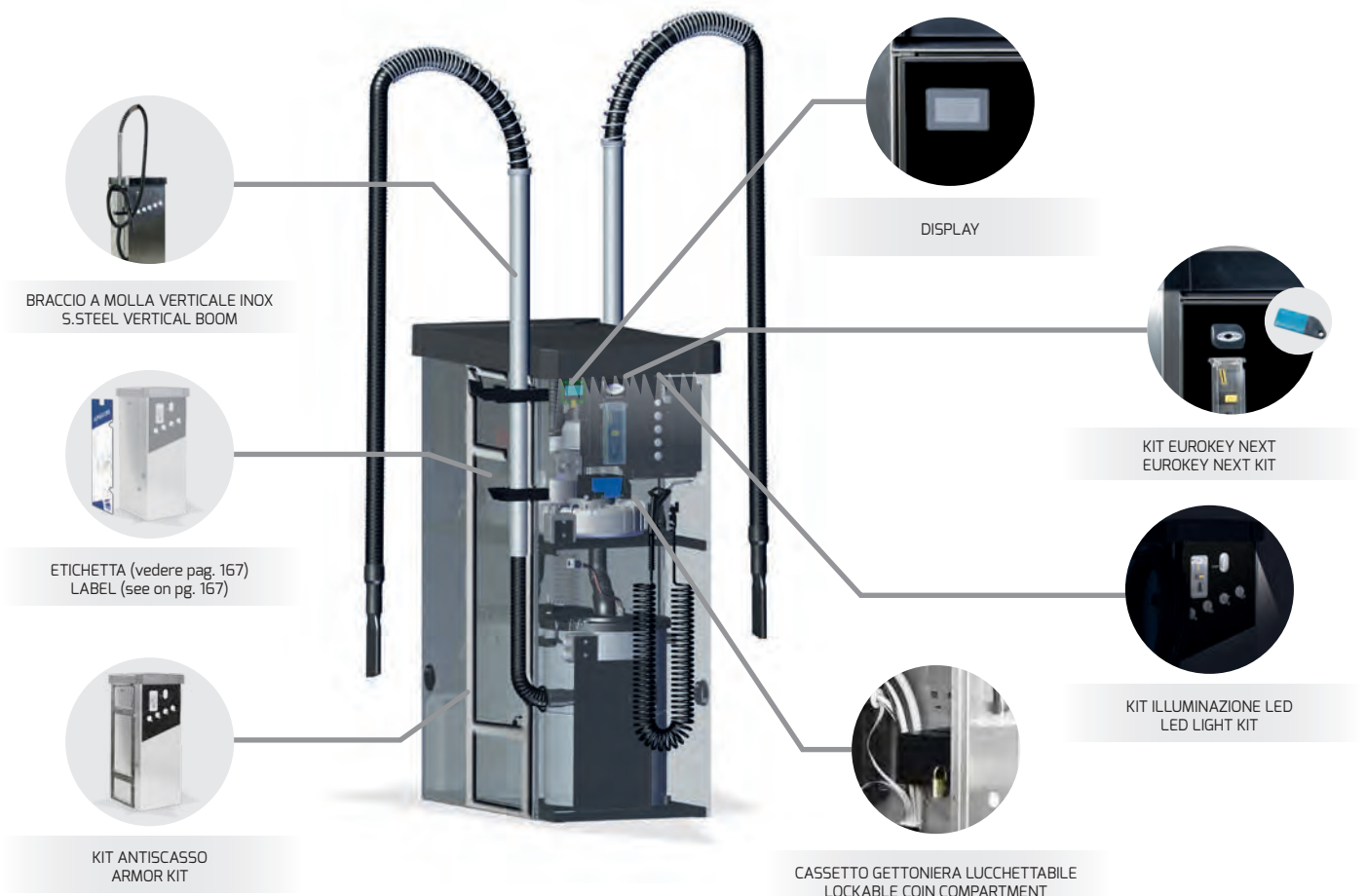

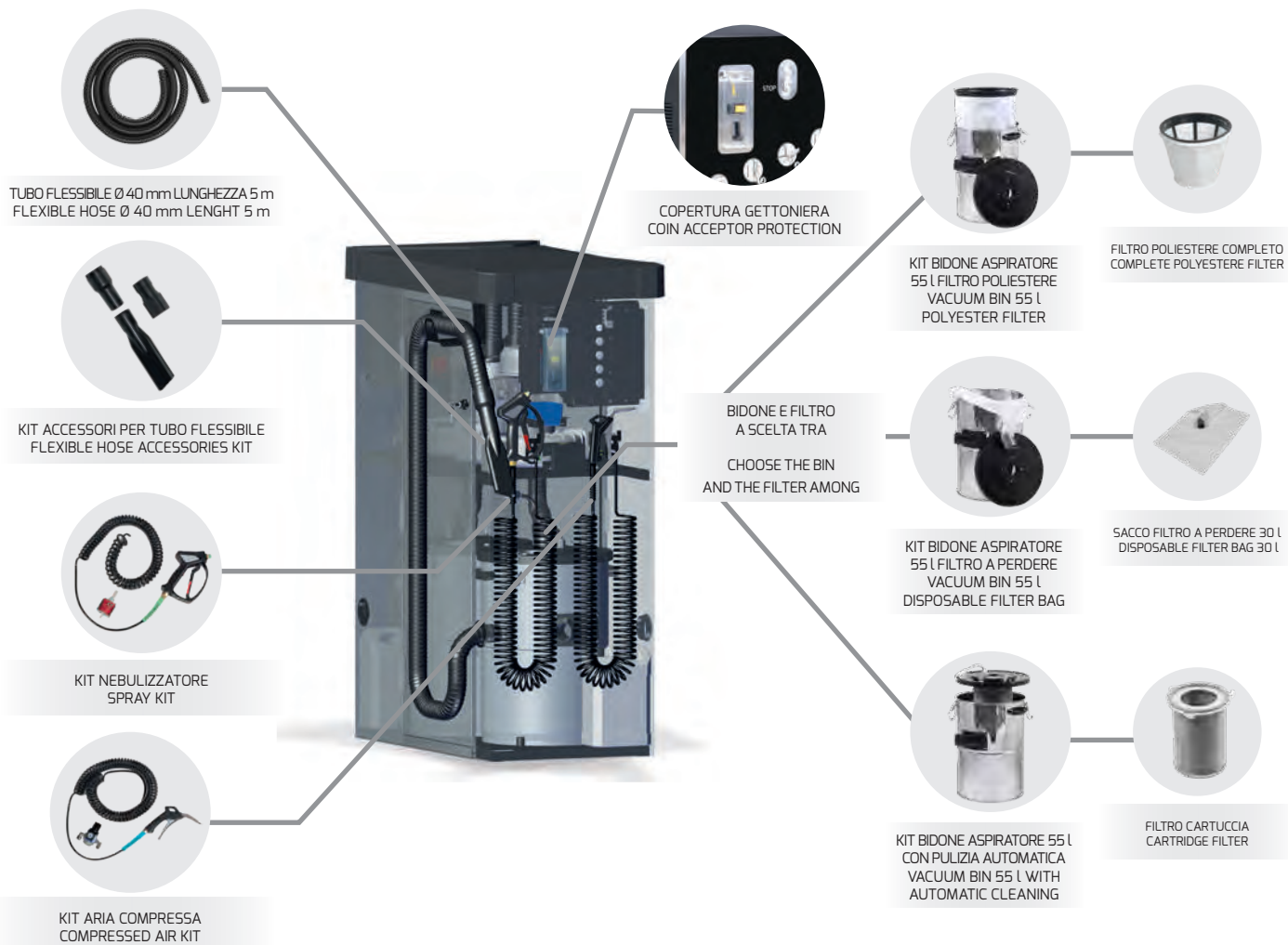

ACCESSORI A RICHIESTA / ACCESSORIES ON DEMAND

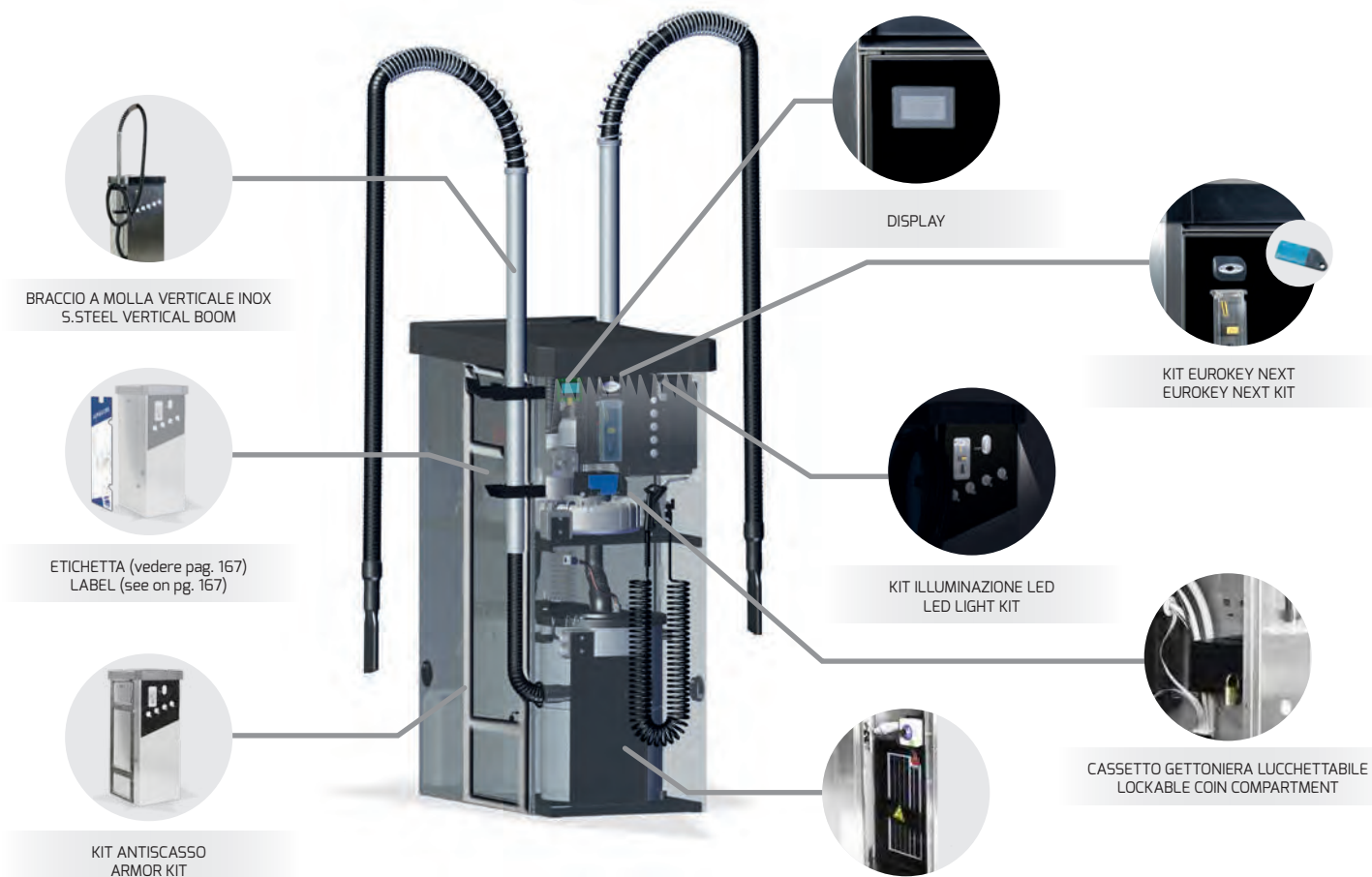

CARATTERISTICHE TECNICHE / TECHNICAL FEATURES

Codice Part No.	Modello Model	Potenza Power	Tensione Voltage	Portata d'Aria Air flow	Alimentazione Power Supply	Peso Totale Total Weight	Filtro Filter
3011720001	AC2	2 x 2,2 kW	400 V - 50 Hz	260 m ³ /h	400 V - 50 Hz 5 POLI R-5-T+N	130 kg	a perdere / disposable
3011720002	AC2	2 x 2,2 kW	400 V - 50 Hz	260 m ³ /h	400 V - 50 Hz 5 POLI R-5-T+N	130 kg	poliestere / polyester
3011820001	AC2	2 x 2,2 kW	400 V - 50 Hz	260 m ³ /h	400 V - 50 Hz 5 POLI R-5-T+N	130 kg	automatico / automatic
3011720003	AC2 AIR	2 x 2,2 kW	400 V - 50 Hz	260 m ³ /h	400 V - 50 Hz 5 POLI R-5-T+N	132 kg	a perdere / disposable
3011720004	AC2 AIR	2 x 2,2 kW	400 V - 50 Hz	260 m ³ /h	400 V - 50 Hz 5 POLI R-5-T+N	132 kg	poliestere / polyester
3011820002	AC2 AIR	2 x 2,2 kW	400 V - 50 Hz	260 m ³ /h	400 V - 50 Hz 5 POLI R-5-T+N	132 kg	automatico / automatic
3011720005	AC2 AIR PLUS	2 x 2,2 kW	400 V - 50 Hz	260 m ³ /h	400 V - 50 Hz 5 POLI R-5-T+N	134 kg	a perdere / disposable
3011720006	AC2 AIR PLUS	2 x 2,2 kW	400 V - 50 Hz	260 m ³ /h	400 V - 50 Hz 5 POLI R-5-T+N	134 kg	poliestere / polyester
3011820003	AC2 AIR PLUS	2 x 2,2 kW	400 V - 50 Hz	260 m ³ /h	400 V - 50 Hz 5 POLI R-5-T+N	134 kg	automatico / automatic

ACCESSORI IN DOTAZIONE / SUPPLIED ACCESSORIES

Codice Part No.	Modello Model	Descrizione Description
0964550011	TUTTI ALL	TUBO FLESSIBILE Ø 40 mm LUNGHEZZA 5 m FLEXIBLE HOSE Ø 40 mm LENGTH 5 m
0090611001	TUTTI ALL	KIT ACCESSORI PER TUBO FLESSIBILE FLEXIBLE HOSE ACCESSORIES KIT
0075611019*	TUTTI ALL	KIT BIDONE ASPIRATORE 55 L FILTRO POLIESTERE VACUUM BIN 55 L POLYESTER FILTER
0330211002*	TUTTI ALL	FILTRO POLIESTERE COMPLETO COMPLETE POLYESTER FILTER
0075611021*	TUTTI ALL	KIT BIDONE ASPIRATORE 55 L FILTRO A PERDERE VACUUM BIN 55 L DISPOSABLE FILTER BAG
0800020002*	TUTTI ALL	SACCO FILTRO A PERDERE 30 L DISPOSABLE FILTER BAG 30 L
0075611020*	TUTTI ALL	KIT BIDONE ASPIRATORE 55 L CON PULIZIA AUTOMATICA VACUUM BIN 55 L WITH AUTOMATIC CLEANING
0330020006	TUTTI ALL	FILTRO CARTUCCIA CARTRIDGE FILTER
0235020005	TUTTI ALL	COPERTURA GETTONIERA COIN ACCEPTOR PROTECTION
0445611030***	AC2 AIR AC2 AIR PLUS	KIT ARIA COMPRESSA COMPRESSED AIR KIT
0445611029	AC2 AIR PLUS	KIT NEBULIZZATORE SPRAY KIT

* A SECONDA DEL CODICE MACCHINA SCELTO
* DEPENDING ON THE SELECTED MACHINE CODE

*** NECESSITA DI COLLEGAMENTO A RETE PNEUMATICA
*** REQUIRES A PNEUMATIC NETWORK CONNECTION

ACCESSORI A RICHIESTA / ACCESSORIES ON DEMAND

Codice Part No.	Modello Model	Descrizione Description
0495022001	TUTTI ALL	KIT EUROKEY NEXT EUROKEY NEXT KIT
0445611047	TUTTI ALL	KIT ILLUMINAZIONE LED LED LIGHT KIT
0170242011	TUTTI ALL	CASSETTO GETTONIERA LUCCHETTABILE LOCKABLE COIN COMPARTMENT
--	TUTTI ALL	ETICHETTA (vedere pag. 167) LABEL (see on pg. 167)
0102611002	TUTTI ALL	BRACCIO A MOLLA VERTICALE INOX S.STEEL VERTICAL BOOM
0445611048	AC2 AIR PLUS	KIT ANTIGELO NO FROST KIT
0445611049	AC2	KIT SOFFIAGGIO ARIA AIR BLOWING KIT
0445611099**	TUTTI ALL	KIT ANTISCASSO ARMOR KIT
0445611050	TUTTI ALL	DISPLAY

** CODICE ESPRESSO RIFERITO A SINGOLO KIT (KIT DA INSTALLARE FRONTE E/O RETRO)
** CODE REFERRED TO A SINGLE KIT (KIT TO INSTALL FRONT AND / OR REAR)

DIMENSIONI
DIMENSIONSIMBALLO (PALLET LEGNO + PLURIBALL)
PACKAGING (WOOD PALLET + PLURIBALL)SCHEMA DI FISSAGGIO BASAMENTO
INSTALLATION SCHEME

A (mm)	B (mm)	C (mm)	X (mm)	Y (mm)	Z (mm)	D (mm)	E (mm)
592	1019	1448	1150	1578	600	905	453

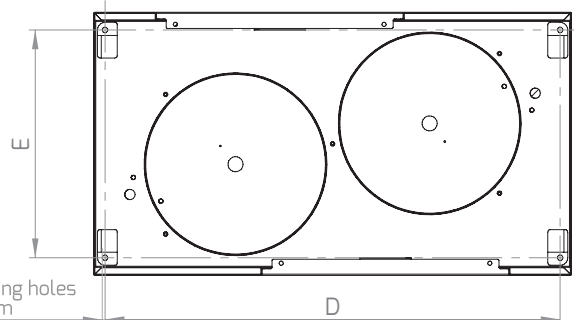
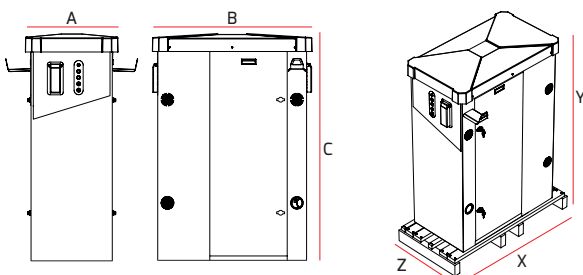

INOX
304

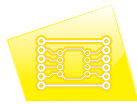

AC2F

AC2F AIR

AC2F AIR PLUS

AF2 - AF2 AIR - AF2 AIR PLUS

ASPIRATORE SELF DOPPIO / DOUBLE SELF VACUUM CLEANER

- ▶ PANNELLO COMANDI SUL LATO LUNGO
- ▶ CHIUSURA A DUE PUNTI ANTIVANDALO
- ▶ TEMPO CICLO PROGRAMMABILE
- ▶ AVVIAMENTO MANUALE A RICHIESTA
- ▶ CALOTTA IN ABS RESISTENTE AI RAGGI UV
- ▶ SPORTELLI ANTERIORI E POSTERIORI FACILMENTE RIMOVIBILI PER INTERVENTI DI MANUTENZIONE
- ▶ NUOVI BIDONI IN ACCIAIO INOX
- ▶ A RICHIESTA TURBINA 2 x 1,5 kW (230V-50Hz/400V - 50Hz)
- ▶ KIT ARIA COMPRESSA INCLUSO, NECESSITA DI COLLEGAMENTO A RETE PNEUMATICA (AF2 AIR - AF2 AIR PLUS)
- ▶ KIT NEBULIZZATORE INCLUSO (AF2 AIR PLUS)
- ▶ CONTROL PANEL ON THE LONG SIDE
- ▶ VANDAL-PROOF DOORS AND LOCKS
- ▶ PROGRAMMABLE CYCLE TIME
- ▶ MANUAL START ON DEMAND
- ▶ ABS COVER, RESISTANT TO UV RAYS
- ▶ FRONT AND REAR COVER PANELS EASY TO REMOVE FOR MAINTENANCE OPERATIONS
- ▶ NEW STAINLESS STEEL BINS
- ▶ 2 x 1,5 kW TURBINE ON DEMAND (230V-50Hz/400V - 50Hz)
- ▶ COMPRESSED AIR KIT ALWAYS SUPPLIED, REQUIRES A PNEUMATIC NETWORK CONNECTION (AF2 AIR - AF2 AIR PLUS)
- ▶ SPRAY KIT INCLUDED (AF2 AIR PLUS)

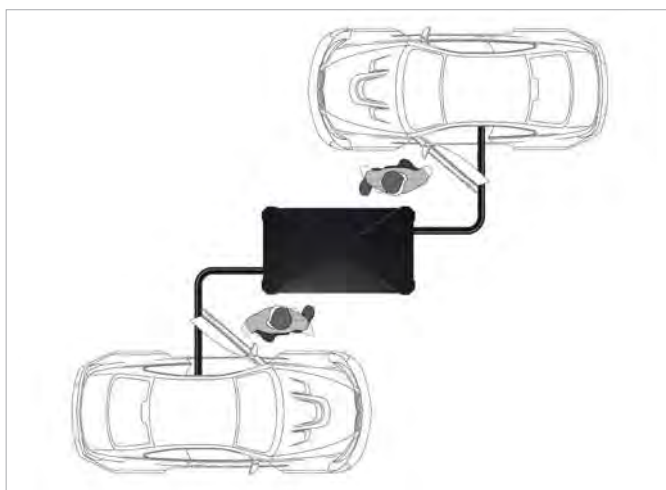

ACCESSORI IN DOTAZIONE / SUPPLIED ACCESSORIES

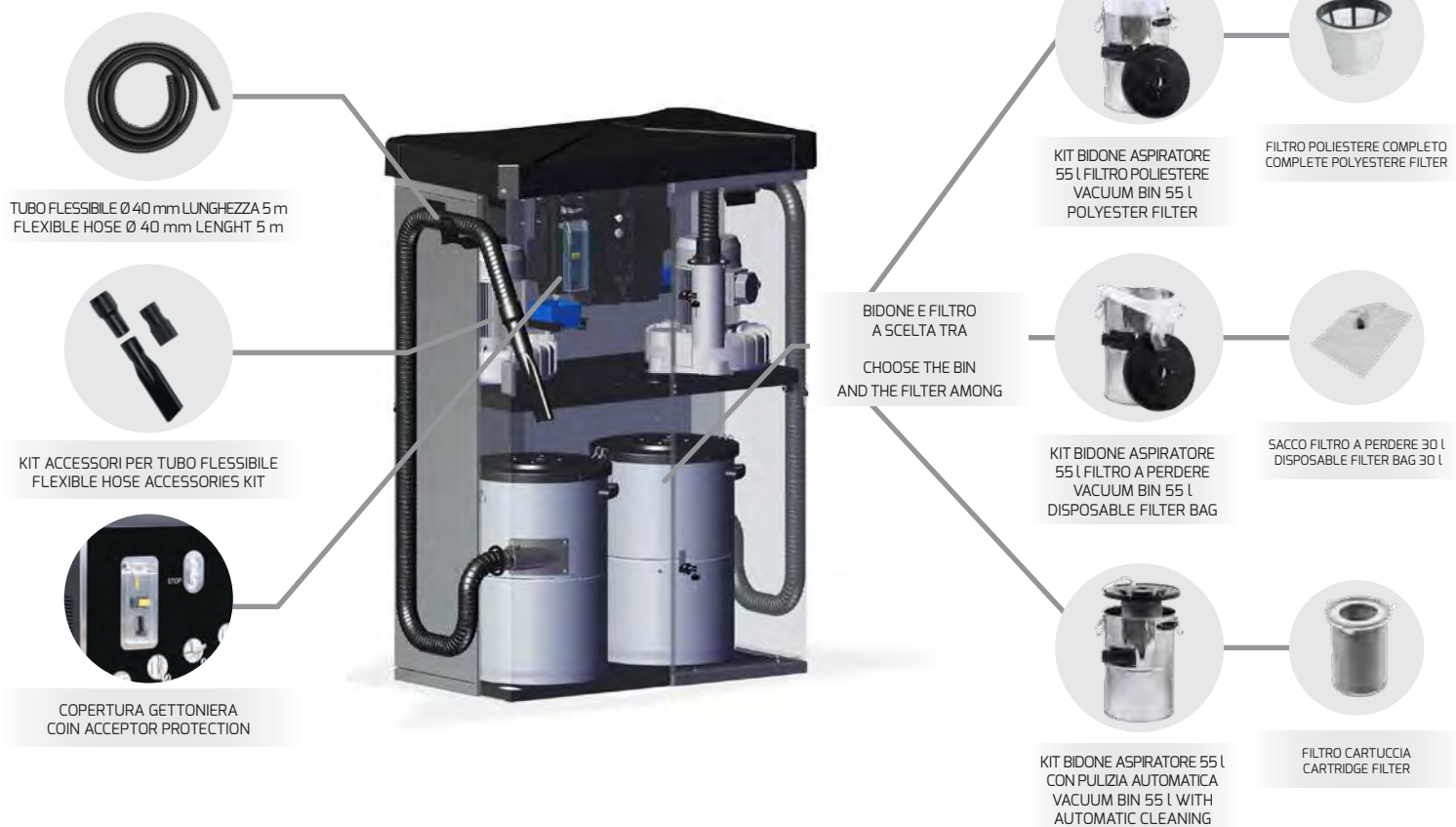

ACCESSORI A RICHIESTA / ACCESSORIES ON DEMAND



ACCESSORI IN DOTAZIONE / SUPPLIED ACCESSORIES

**TUBO FLESSIBILE Ø 40 mm LUNGHEZZA 5 m
FLEXIBLE HOSE Ø 40 mm LENGHT 5 m**

**KIT ACCESSORI PER TUBO FLESSIBILE
FLEXIBLE HOSE ACCESSORIES KIT**

**COPERTURA GETTONIERA
COIN ACCEPTOR PROTECTION**

**BIDONE E FILTRO
A SCELTA TRA
CHOOSE THE BIN
AND THE FILTER AMONG**

- KIT BIDONE ASPIRATORE 55 L FILTRO POLIESTERE
VACUUM BIN 55 L POLYESTER FILTER**
- FILTRO POLIESTERE COMPLETO
COMPLETE POLYESTERE FILTER**
- KIT BIDONE ASPIRATORE 55 L FILTRO A PERDERE
VACUUM BIN 55 L DISPOSABLE FILTER BAG**
- SACCO FILTRO A PERDERE 30 L
DISPOSABLE FILTER BAG 30 L**
- KIT BIDONE ASPIRATORE 55 L CON PULIZIA AUTOMATICA
VACUUM BIN 55 L WITH AUTOMATIC CLEANING**
- FILTRO CARTUCCIA
CARTRIDGE FILTER**

**KIT ARIA COMPRESSA
COMPRESSED AIR KIT**

ACCESSORI A RICHIESTA / ACCESSORIES ON DEMAND

**BRACCIO A MOLLA VERTICALE INOX
S. STEEL VERTICAL BOOM**

**ETICHETTA (vedere pag. 167)
LABEL (see on pg. 167)**

**CASSETTO GETTONIERA LUCCHETTABILE
LOCKABLE COIN COMPARTMENT**

DISPLAY

**KIT EUROKEY NEXT
EUROKEY NEXT KIT**

**KIT ILLUMINAZIONE LED
LED LIGHT KIT**

**TUBO FLESSIBILE Ø 40 mm LUNGHEZZA 5 m
FLEXIBLE HOSE Ø 40 mm LENGHT 5 m**

**KIT ACCESSORI PER TUBO FLESSIBILE
FLEXIBLE HOSE ACCESSORIES KIT**

**KIT ARIA COMPRESSA
COMPRESSED AIR KIT**

**KIT NEBULIZZATORE
SPRAY KIT**

**COPERTURA GETTONIERA
COIN ACCEPTOR PROTECTION**

**BIDONE E FILTRO
A SCELTA TRA
CHOOSE THE BIN
AND THE FILTER AMONG**

**KIT BIDONE ASPIRATORE
55 L FILTRO POLIESTERE
VACUUM BIN 55 L
POLYESTER FILTER**

**FILTRO POLIESTERE COMPLETO
COMPLETE POLYESTER FILTER**

**KIT BIDONE ASPIRATORE
55 L FILTRO A PERDERE
VACUUM BIN 55 L
DISPOSABLE FILTER BAG**

**SACCO FILTRO A PERDERE 30 L
DISPOSABLE FILTER BAG 30 L**

**KIT BIDONE ASPIRATORE 55 L
CON PULIZIA AUTOMATICA
VACUUM BIN 55 L WITH
AUTOMATIC CLEANING**

**FILTRO CARTUCCIA
CARTRIDGE FILTER**

ACCESSORI A RICHIESTA / ACCESSORIES ON DEMAND

**BRACCIO A MOLLA VERTICALE INOX
S.STEEL VERTICAL BOOM**

**ETICHETTA (vedere pag. 167)
LABEL (see on pg. 167)**

**CASSETTO GETTONIERA LUCCHETTABILE
LOCKABLE COIN COMPARTMENT**

DISPLAY

**KIT EUROKEY NEXT
EUROKEY NEXT KIT**

**KIT ILLUMINAZIONE LED
LED LIGHT KIT**

**KIT ANTIGELO
NO FROST KIT**

CARATTERISTICHE TECNICHE / TECHNICAL FEATURES

Codice Part No.	Modello Model	Potenza Power	Tensione Voltage	Portata d'Aria Air flow	Alimentazione Power Supply	Peso Totale Total Weight	Filtro Filter
3011720101	AF2	2 x 2,2 kW	400V	320 m ³ /h	400V - 50 Hz	130 kg	a perdere / disposable
3011720102	AF2	2 x 2,2 kW	400V	320 m ³ /h	400V - 50 Hz	130 kg	poliestere / polyester
3011820101	AF2	2 x 2,2 kW	400V	320 m ³ /h	400V - 50 Hz	130 kg	autopulente / automatic
3011720103	AF2 AIR	2 x 2,2 kW	400V	320 m ³ /h	400V - 50 Hz	130 kg	a perdere / disposable
3011720104	AF2 AIR	2 x 2,2 kW	400V	320 m ³ /h	400V - 50 Hz	130 kg	poliestere / polyester
3011820102	AF2 AIR	2 x 2,2 kW	400V	320 m ³ /h	400V - 50 Hz	130 kg	autopulente / automatic
3011720105	AF2 AIR PLUS	2 x 2,2 kW	400V	320 m ³ /h	400V - 50 Hz	130 kg	a perdere / disposable
3011720106	AF2 AIR PLUS	2 x 2,2 kW	400V	320 m ³ /h	400V - 50 Hz	130 kg	poliestere / polyester
3011820103	AF2 AIR PLUS	2 x 2,2 kW	400V	320 m ³ /h	400V - 50 Hz	130 kg	autopulente / automatic

ACCESSORI IN DOTAZIONE / SUPPLIED ACCESSORIES

Codice Part No.	Modello Model	Descrizione Description
0964550011	TUTTI ALL	TUBO FLESSIBILE Ø 40 mm LUNGHEZZA 5 m FLEXIBLE HOSE Ø 40 mm LENGHT 5 m
0090611001	TUTTI ALL	KIT ACCESSORI PER TUBO FLESSIBILE FLEXIBLE HOSE ACCESSORIES KIT
0075611019*	TUTTI ALL	KIT BIDONE ASPIRATORE 55 L FILTRO POLIESTERE VACUUM BIN 55 L POLYESTER FILTER
0330211002*	TUTTI ALL	FILTRO POLIESTERE COMPLETO COMPLETE POLYESTER FILTER
0075611021*	TUTTI ALL	KIT BIDONE ASPIRATORE 55 L FILTRO A PERDERE VACUUM BIN 55 L DISPOSABLE FILTER BAG
0800020002*	TUTTI ALL	SACCO FILTRO A PERDERE 30 L DISPOSABLE FILTER BAG 30 L
0075611020*	TUTTI ALL	KIT BIDONE ASPIRATORE 55 L CON PULIZIA AUTOMATICA VACUUM BIN 55 L WITH AUTOMATIC CLEANING
0330020006	TUTTI ALL	FILTRO CARTUCCIA CARTRIDGE FILTER
0235020005	TUTTI ALL	COPERTURA GETTONIERA COIN ACCEPTOR PROTECTION
0445611030**	AF2 AIR AF2 AIR PLUS	KIT ARIA COMPRESSA COMPRESSED AIR KIT
0445611029	AF2 AIR PLUS	KIT NEBULIZZATORE SPRAY KIT

* A SECONDA DEL CODICE MACCHINA SCELTO
* DEPENDING ON THE SELECTED MACHINE CODE

** NECESSITA DI COLLEGAMENTO A RETE PNEUMATICA
** REQUIRES A PNEUMATIC NETWORK CONNECTION

ACCESSORI A RICHIESTA / ACCESSORIES ON DEMAND

Codice Part No.	Modello Model	Descrizione Description
0495022001	TUTTI ALL	KIT EUROKEY NEXT EUROKEY NEXT KIT
0445611047	TUTTI ALL	KIT ILLUMINAZIONE LED LED LIGHT KIT
0170242011	TUTTI ALL	CASSETTO GETTONIERA LUCCHETTABILE LOCKABLE COIN COMPARTMENT
--	TUTTI ALL	ETICHETTA (vedere pag. 167) LABEL (see on pg. 167)
0102611002	TUTTI ALL	BRACCIO A MOLLA VERTICALE INOX S.STEEL VERTICAL BOOM
0445611048	AF2 AIR PLUS	KIT ANTIGELO NO FROST KIT
0445611049	AF2	KIT SOFFIAGGIO ARIA AIR BLOWING KIT
0445611050	TUTTI ALL	DISPLAY

DIMENSIONI
DIMENSIONSIMBALLO (PALLET LEGNO + PLURIBALL)
PACKAGING (WOOD PALLET + PLURIBALL)SCHEMA DI FISSAGGIO BASAMENTO
INSTALLATION SCHEME

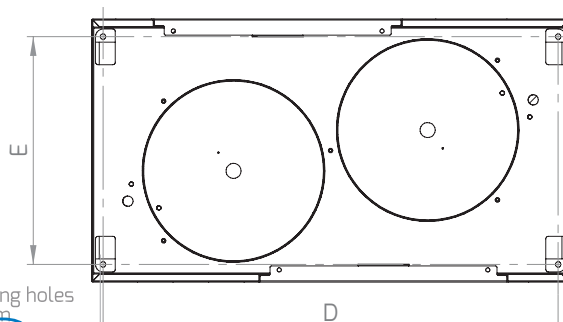
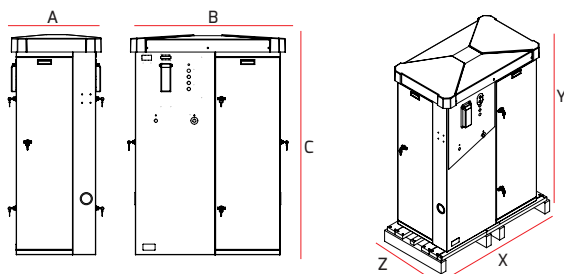

A (mm)	B (mm)	C (mm)	X (mm)	Y (mm)	Z (mm)	D (mm)	E (mm)
592	1019	1448	1150	1578	600	905	453

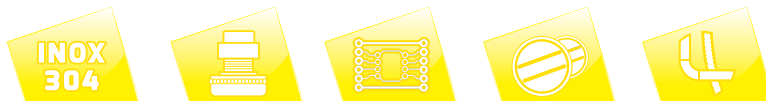



AL1

ASPIRATORE SELF SINGOLO / SINGLE SELF VACUUM CLEANER

- ❖ CHIUSURA A DUE PUNTI ANTIVANDALO
- ❖ TEMPO CICLO PROGRAMMABILE
- ❖ AVVIAMENTO MANUALE A RICHIESTA
- ❖ CALOTTA IN ABS RESISTENTE AI RAGGI UV
- ❖ QUADRO ELETTRICO E GETTONIERA ELETTRONICA INTEGRATI
- ❖ TRE CONFIGURAZIONI DI USCITA DEL TUBO ASPIRATORE

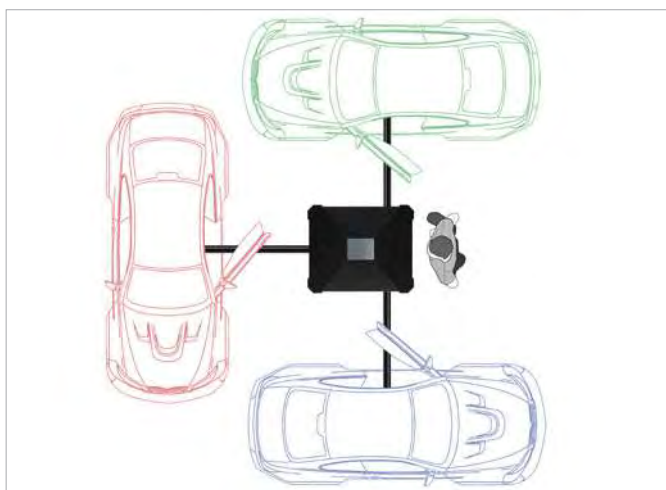
- ❖ SPORTELLI ANTERIORI E POSTERIORI FACILMENTE RIMOVIBILI PER INTERVENTI DI MANUTENZIONE
- ❖ NUOVI BIDONI IN ACCIAIO INOX
- ❖ VANDAL-PROOF DOORS AND LOCKS
- ❖ PROGRAMMABLE CYCLE TIME
- ❖ MANUAL START ON DEMAND
- ❖ ABS COVER, RESISTANT TO UV RAYS
- ❖ INTEGRATED ELECTRONIC CONTROL BOARD
- ❖ THREE CONFIGURATIONS FOR VACUUM HOSE OUTLET

- ❖ FRONT AND REAR COVER PANELS EASY TO REMOVE FOR MAINTENANCE OPERATIONS
- ❖ NEW STAINLESS STEEL BINS

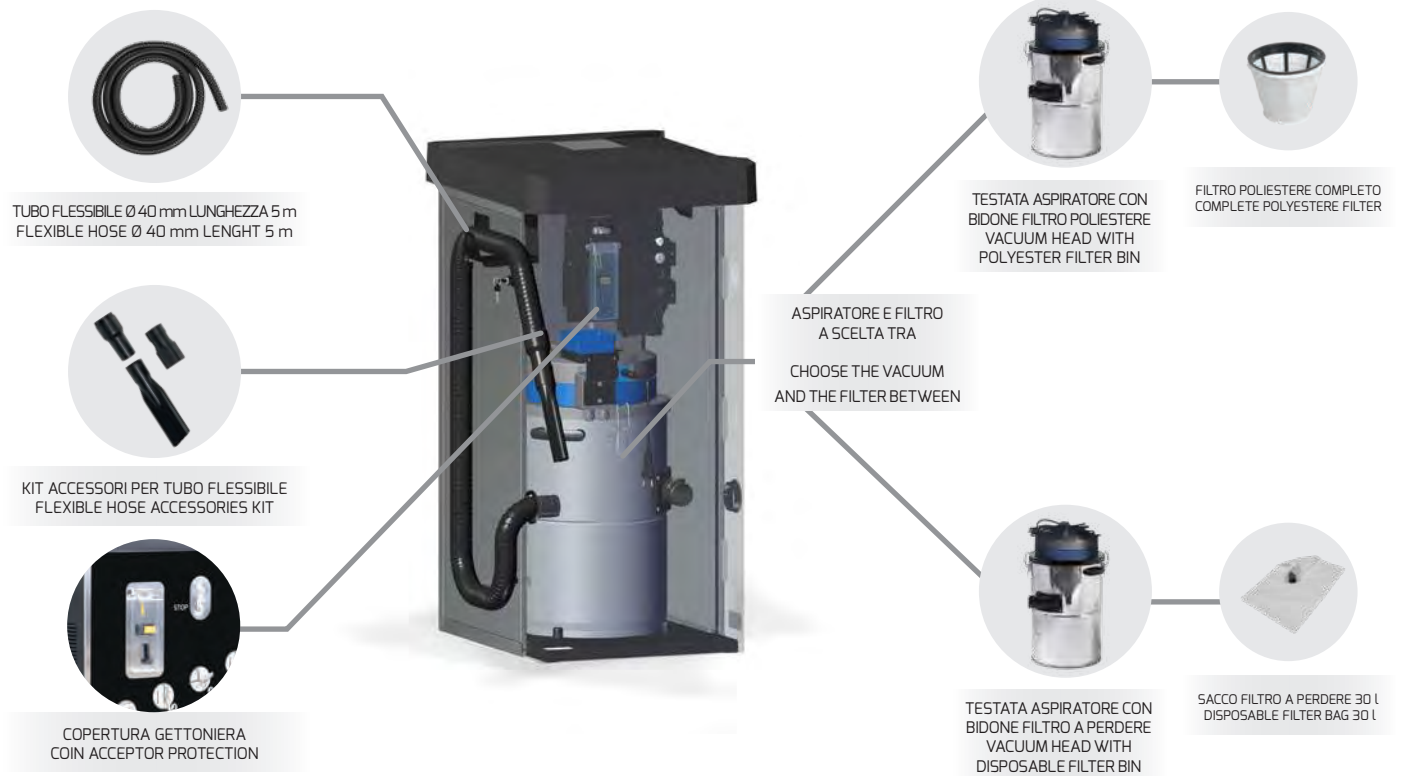

ACCESSORI IN DOTAZIONE / SUPPLIED ACCESSORIES



ACCESSORI A RICHIESTA / ACCESSORIES ON DEMAND



CARATTERISTICHE TECNICHE / TECHNICAL FEATURES

Codice Part No.	Potenza Power	Tensione Voltage	Portata d'Aria Air flow	Alimentazione Power Supply	Peso Totale Total Weight	Filtro Filter
3011350002	1,2 kW	230 V - 50 Hz	220 m ³ /h	230 V - 50 Hz	50 kg	a perdere / disposable
3011350001	1,2 kW	230 V - 50 Hz	220 m ³ /h	230 V - 50 Hz	50 kg	poliestere / polyester

ACCESSORI IN DOTAZIONE / SUPPLIED ACCESSORIES

Codice Part No.	Descrizione Description
0964550011	TUBO FLESSIBILE Ø 40 mm LUNGHEZZA 5 m FLEXIBLE HOSE Ø 40 mm LENGHT 5 m
0090611001	KIT ACCESSORI PER TUBO FLESSIBILE FLEXIBLE HOSE ACCESSORIES KIT
0942611001*	TESTATA ASPIRATORE CON BIDONE FILTRO POLIESTERE VACUUM HEAD WITH POLYESTER FILTER BIN
0330211002*	FILTRO POLIESTERE COMPLETO COMPLETE POLYESTERE FILTER
0942611003*	TESTATA ASPIRATORE CON BIDONE FILTRO A PERDERE VACUUM HEAD WITH DISPOSABLE FILTER BIN
0800020002*	SACCO FILTRO A PERDERE 30 l DISPOSABLE FILTER BAG 30 l
0235020005	COPERTURA GETTONIERA COIN ACCEPTOR PROTECTION

* A SECONDA DEL CODICE MACCHINA SCELTO
* DEPENDING ON THE SELECTED MACHINE CODE

ACCESSORI A RICHIESTA / ACCESSORIES ON DEMAND

Codice Part No.	Descrizione Description
--	ETICHETTA (vedere pag. 167) LABEL (see on pg. 167)

DIMENSIONI
DIMENSIONSIMBALLO (PALLET LEGNO + PLURIBALL)
PACKAGING (WOOD PALLET + PLURIBALL)SCHEMA DI FISSAGGIO BASAMENTO
INSTALLATION SCHEME



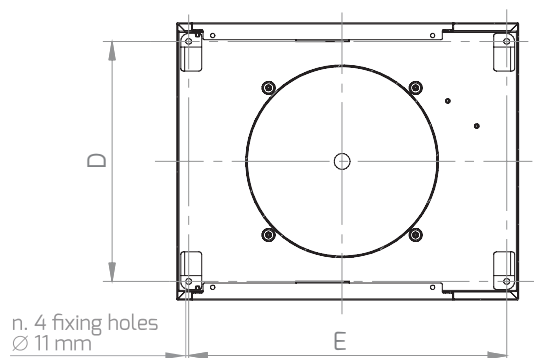
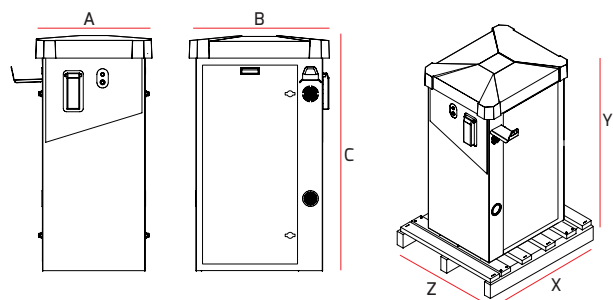

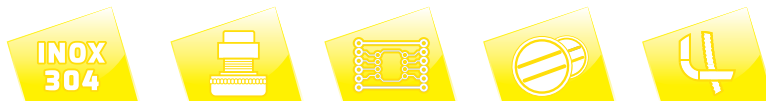
A (mm)	B (mm)	C (mm)	X (mm)	Y (mm)	Z (mm)	D (mm)	E (mm)
592	714	1198	900	1328	800	453	600





AL2

ASPIRATORE SELF DOPPIO / DOUBLE SELF VACUUM CLEANER

- ❖ CHIUSURA A DUE PUNTI ANTIVANDALO
- ❖ TEMPO CICLO PROGRAMMABILE
- ❖ AVVIAMENTO MANUALE A RICHIESTA
- ❖ CALOTTA IN ABS RESISTENTE AI RAGGI UV
- ❖ QUADRO ELETTRICO E GETTONIERA ELETTRONICA INTEGRATI
- ❖ DUE CONFIGURAZIONI DI USCITA DEL TUBO ASPIRATORE
 -  SINISTRA
 -  DESTRA
- ❖ SPORTELLI ANTERIORI E POSTERIORI FACILMENTE RIMOVIBILI PER INTERVENTI DI MANUTENZIONE
- ❖ NUOVI BIDONI IN ACCIAIO INOX
- ❖ VANDAL-PROOF DOORS AND LOCKS
- ❖ PROGRAMMABLE CYCLE TIME
- ❖ MANUAL START ON DEMAND
- ❖ ABS COVER, RESISTANT TO UV RAYS
- ❖ INTEGRATED ELECTRONIC CONTROL BOARD
- ❖ TWO CONFIGURATIONS FOR VACUUM HOSE OUTLET
 -  LEFT
 -  RIGHT
- ❖ FRONT AND REAR COVER PANELS EASY TO REMOVE FOR MAINTENANCE OPERATIONS
- ❖ NEW STAINLESS STEEL BINS

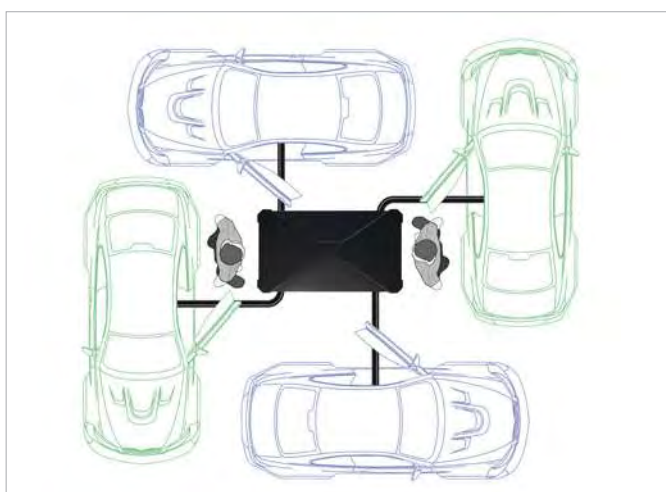

ACCESSORI IN DOTAZIONE / SUPPLIED ACCESSORIES



ACCESSORI A RICHIESTA / ACCESSORIES ON DEMAND



CARATTERISTICHE TECNICHE / TECHNICAL FEATURES

Codice Part No.	Potenza Power	Tensione Voltage	Portata d'Aria Air flow	Alimentazione Power Supply	Peso Totale Total Weight	Filtro Filter
3011650002	2 x 1,2 kW	230 V - 50 Hz	220 m ³ /h	230 V - 50 Hz	80 kg	a perdere / disposable
3011650001	2 x 1,2 kW	230 V - 50 Hz	220 m ³ /h	230 V - 50 Hz	80 kg	poliestere / polyester

ACCESSORI IN DOTAZIONE / SUPPLIED ACCESSORIES

Codice (1 pz.) Part No. (1 piece)	Descrizione Description	Quantità Quantity
0964550011	TUBO FLESSIBILE Ø 40 mm LUNGHEZZA 5 m FLEXIBLE HOSE Ø 40 mm LENGHT 5 m	2
0090611001	KIT ACCESSORI PER TUBO FLESSIBILE FLEXIBLE HOSE ACCESSORIES KIT	2
0942611001*	TESTATA ASPIRATORE CON BIDONE FILTRO POLIESTERE VACUUM HEAD WITH POLYESTER FILTER BIN	2
0330211002*	FILTRO POLIESTERE COMPLETO COMPLETE POLYESTERE FILTER	2
0942611003*	TESTATA ASPIRATORE CON BIDONE FILTRO A PERDERE VACUUM HEAD WITH DISPOSABLE FILTER BIN	2
0800020002*	SACCO FILTRO A PERDERE 30 l DISPOSABLE FILTER BAG 30 l	2
0235020005	COPERTURA GETTONIERA COIN ACCEPTOR PROTECTION	2

ACCESSORI A RICHIESTA / ACCESSORIES ON DEMAND

Codice (1 pz.) Part No. (1 piece)	Descrizione Description
--	ETICHETTA (vedere pag. 167) LABEL (see on pg. 167)

* A SECONDA DEL CODICE MACCHINA SCELTO
* DEPENDING ON THE SELECTED MACHINE CODE

DIMENSIONI
DIMENSIONSIMBALLO (PALLET LEGNO + PLURIBALL)
PACKAGING (WOOD PALLET + PLURIBALL)SCHEMA DI FISSAGGIO BASAMENTO
INSTALLATION SCHEME

A (mm)	B (mm)	C (mm)	X (mm)	Y (mm)	Z (mm)	D (mm)	E (mm)
592	1019	1198	1150	1328	600	905	453

