

2018



CATALOGO
CATALOGUE

**CAR WASH
EQUIPMENT**

LAVATAPPETI
MAT CLEANERS

02 LAVATAPPETI MAT CLEANERS



L'**ACCIAIO INOX** che utilizziamo per le nostre macchine è del tipo AISI 304 quindi a basso contenuto di carbonio.
I principali vantaggi di questo materiale per le nostre applicazioni sono :

- Elevata resistenza alle intemperie e corrosione
- Facilità di ripulitura e ottimo coefficiente igienico.

The **STAINLESS STEEL** used in the construction of our machines is of the type AISI 304 with low carbon content.
The main advantages of this material for our applications are:

- High level of resistance to extreme weather and corrosion
- Ease of cleaning and maintenance and excellent hygiene properties.

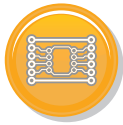

SCHEDA ELETTRONICA, dotata di temporizzatore elettronico, svolge una o più azioni a intervalli di tempo prefissati, facilmente regolabile secondo le esigenze del cliente.

The **ELECTRONIC CIRCUIT BOARD**, supplied with an electronic timer, manages one or more functions at prefixed intervals, and is easily adjustable according to the client's needs.



La **GETTONIERA ELETTRONICA**, offerta di serie, combina una straordinaria selettività ad un'estrema versatilità di programmazione.

The **ELECTRONIC TOKEN AND COIN-OP** mechanism, supplied as standard equipment, combines extraordinary versatility with extreme programming flexibility.

MC



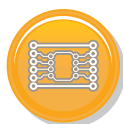

MC

LAVATAPPETI / MAT CLEANER

CARATTERISTICHE / FEATURES

PULIZIA TAPPETINI FINO A 80 CM DI LARGHEZZA/ CAR MAT CLEANING UP TO 80 CM IN WIDTH

UTILIZZABILE PER TAPPETINI IN TESSUTO O GOMMA / SUITABLE FOR CLOTH OR RUBBER CAR MATS

TEMPO CICLO PROGRAMMABILE / PROGRAMMABLE CYCLE TIME

AVVIAMENTO MANUALE A RICHIESTA / MANUAL START ON DEMAND

CALOTTA IN ABS RESISTENTE AI RAGGI UV / ABS COVER, RESISTANT TO UV RAYS

RIMOZIONE DEL GRUPPO SPAZZOLA FACILITATA / EASY REMOVAL OF BRUSH UNIT

SPORTELLI LATERALI INCERNIERATI PER UNA FACILE MANUTENZIONE / HINGED SIDE DOORS FOR EASY MAINTENANCE



PREDISPOSIZIONE PER PULSANTIERA PERSONALIZZATA
A SECONDA DEGLI ACCESSORI INSTALLATI

PREDISPOSED FOR PERSONALIZED BUTTON PAD BASED ON
INSTALLED ACCESSORIES

- ON/OFF ACQUA / WATER
- ON/OFF NEBULIZZATORE / SPRAY KIT
- ON/OFF ARIA COMPRESSA / COMPRESSED AIR

ACCESSORI A RICHIESTA / ACCESSORIES ON DEMAND



N° N.	Codice Part No.	Descrizione Description
1	0445611018	KIT ACQUA WATER KIT
2	0445611020	KIT ANTIGELO NO FROST KIT KIT
3	0445611019	KIT ANTIBATTERICO ANTIBACTERIAL KIT
4	0060242003	BASAMENTO RINFORZATO MC MC REINFORCED SUPPORT BASE
5	0140242002	CASSETTO GETTONI LUCCHETTABILE LOCKABLE TOKEN DRAWER
6	0765611005	KIT ACCESSORIO MENSOLA SHELF KIT
7	0235020001	COPERTURA GETTONIERA COIN ACCEPTOR PROTECTION
8	0455611032	KIT NEBULIZZATORE SPRAY KIT
9	0445611033	KIT ARIA COMPRESSA COMPRESSED AIR KIT
10	0495022001	KIT EUROKEY NEXT EUROKEY NEXT KIT

CARATTERISTICHE TECNICHE / TECHNICAL FEATURES

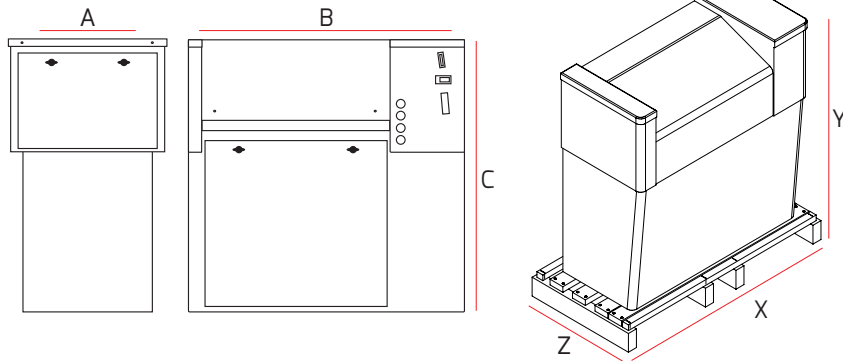
DIMENSIONI
DIMENSIONS

A (mm)	B (mm)	C (mm)
520	1070	1065

IMBALLO con PLURIBALL
PACKAGING with PLURIBALL

X (mm)	Y (mm)	Z (mm)
1200	1165	600

SCHEMA DI FISSAGGIO BASAMENTO
INSTALLATION SCHEME

QUOTE (mm) DIMENSIONS (mm)

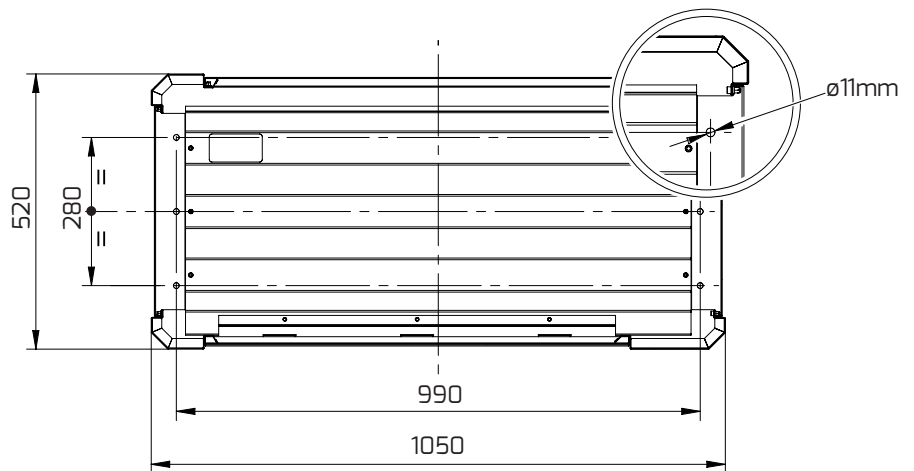

TENSIONE / VOLTAGE	230 V - 50 Hz	400 V - 50 Hz
POTENZA / POWER	400W	400W
PESO TOTALE / TOTAL WEIGHT	80 kg	80 kg

Codice
Part No.3020310001
3020320001Motore
Motormonofase / single phase
trifase / three phase