

2018



CATALOGO  
CATALOGUE

**CAR WASH  
EQUIPMENT**

LAVAINTERNI  
CAR SEAT WASH

# 03 LAVAINTERNI CAR SEAT WASH

01

AC DRY LAVAINTERNI SELF A SCHIUMA SECCA · DRY FOAM CAR SEAT WASH

057

02

AL WET LAVAINTERNI SELF INIEZIONE · ESTRAZIONE · INJECTION · EXTRACTION FOAM CAR SEAT WASH

061



L'**ACCIAIO INOX** che utilizziamo per le nostre macchine è del tipo AISI 304 quindi a basso contenuto di carbonio.  
I principali vantaggi di questo materiale per le nostre applicazioni sono :  
 • Elevata resistenza alle intemperie e corrosione  
 • Facilità di ripulitura e ottimo coefficiente igienico.

The **STAINLESS STEEL** used in the construction of our machines is of the type AISI 304 with low carbon content.  
The main advantages of this material for our applications are:  
 • High level of resistance to extreme weather and corrosion  
 • Ease of cleaning and maintenance and excellent hygiene properties.



Il sistema di **INIEZIONE-ESTRAZIONE DI SCHIUMA**, miscelata con acqua, offre una notevole azione detergente anche in profondità nel tessuto e facile rimozione dello sporco.

in this case the **FOAM** is called **DRY** as it is produced by a compressed air system and is not mixed with water, with the advantage of requiring less drying time.

In questo caso la **SCHIUMA** viene definita **SECCA** in quanto prodotta da un sistema ad aria compressa e quindi non miscelata con acqua , il vantaggio è quindi che il tessuto richiede molto meno tempo per asciugare.

In this case, the **FOAM** is defined as **DRY** because it is generated by a system working with compressed air and not mixed with water. The advantage is that the tissue requires much less time to dry.

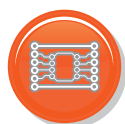

**SCHEDA ELETTRONICA**, dotata di temporizzatore elettronico, svolge una o più azioni a intervalli di tempo prefissati, facilmente regolabile secondo le esigenze del cliente.

The **ELECTRONIC CIRCUIT BOARD**, supplied with an electronic timer, manages one or more functions at prefixed intervals, and is easily adjustable according to the client's needs.



La **GETTONIERA ELETTRONICA**, offerta di serie, combina una straordinaria selettività ad un'estrema versatilità di programmazione.

The **ELECTRONIC TOKEN AND COIN-OP** mechanism, supplied as standard equipment, combines extraordinary versatility with extreme programming flexibility.

	AC DRY	AL WET
L' <b>ACCIAIO INOX</b> che utilizziamo per le nostre macchine è del tipo AISI 304 quindi a basso contenuto di carbonio. I principali vantaggi di questo materiale per le nostre applicazioni sono : • Elevata resistenza alle intemperie e corrosione • Facilità di ripulitura e ottimo coefficiente igienico.	✓	✓
The <b>STAINLESS STEEL</b> used in the construction of our machines is of the type AISI 304 with low carbon content. The main advantages of this material for our applications are: • High level of resistance to extreme weather and corrosion • Ease of cleaning and maintenance and excellent hygiene properties.		
Il sistema di <b>INIEZIONE-ESTRAZIONE DI SCHIUMA</b> , miscelata con acqua, offre una notevole azione detergente anche in profondità nel tessuto e facile rimozione dello sporco.  in this case the <b>FOAM</b> is called <b>DRY</b> as it is produced by a compressed air system and is not mixed with water, with the advantage of requiring less drying time.		✓
In questo caso la <b>SCHIUMA</b> viene definita <b>SECCA</b> in quanto prodotta da un sistema ad aria compressa e quindi non miscelata con acqua , il vantaggio è quindi che il tessuto richiede molto meno tempo per asciugare.  In this case, the <b>FOAM</b> is defined as <b>DRY</b> because it is generated by a system working with compressed air and not mixed with water. The advantage is that the tissue requires much less time to dry.	✓	
<b>SCHEDA ELETTRONICA</b> , dotata di temporizzatore elettronico, svolge una o più azioni a intervalli di tempo prefissati, facilmente regolabile secondo le esigenze del cliente.  The <b>ELECTRONIC CIRCUIT BOARD</b> , supplied with an electronic timer, manages one or more functions at prefixed intervals, and is easily adjustable according to the client's needs.	✓	✓
La <b>GETTONIERA ELETTRONICA</b> , offerta di serie, combina una straordinaria selettività ad un'estrema versatilità di programmazione.  The <b>ELECTRONIC TOKEN AND COIN-OP</b> mechanism, supplied as standard equipment, combines extraordinary versatility with extreme programming flexibility.	✓	✓

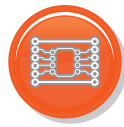

# AC DRY

LAVAINTERNI SELF A SCHIUMA SECCA / DRY FOAM CAR SEAT WASH

**NEW**

## CARATTERISTICHE / FEATURES

POMPA CON BY-PASS 4 BAR 1.5 LT/MIN / PUMP WITH BY-PASS 4 BAR 1.5 LT/MIN

MOTORE ASPIRAZIONE BISTADIO 1500 W / TWO-STAGE VACUUM MOTOR 1500W

AVVIAMENTO MANUALE A RICHIESTA / MANUAL START ON DEMAND

COPERTURA IN ABS RESISTENTE AI RAGGI UV / ABS COVER, RESISTANT TO UV RAYS

PRODOTTO CHIMICO NON FORNITO / CHEMICAL PRODUCT NOT INCLUDED



COMPRESSORE 8 BAR CON SERBATOIO DA 6 LT  
8 BAR COMPRESSOR WITH 6 LT TANK



SERBATOIO PRODOTTO CHIMICO 14 LT - SERBATOIO RACCOLTA SPORCO 14 LT  
14 LT CHEMICAL PRODUCT TANK - 14 LT DIRT COLLECTING TANK

## ACCESSORI IN DOTAZIONE / SUPPLIED ACCESSORIES



N° N.	Codice Part No.	Descrizione Description
1	0964611003	TUBO COMPLETO LAVAINTERNI COMPLETE CAR SEAT WASH HOSE
2	0090027003	BOCCHETTA LAVAINTERNI AC DRY AC DRY CAR SEAT WASH
3	0860020002	SPAZZOLA COMPLETA LAVAINTERNI AC DRY AC DRY COMPLETE CAR SEAT WASH BRUSH
4	0235020001	COPERTURA GETTONIERA COIN ACCEPTOR PROTECTION

## ACCESSORI A RICHIESTA / ACCESSORIES ON DEMAND



N° N.	Codice Part No.	Descrizione Description
1	0495022001	KIT EUROKEY NEXT EUROKEY NEXT KIT
2	0490211002	ILLUMINAZIONE LED
3	0170242011	CASSETTO GETTONIERA LUCCHETTABILE
4	--	ETICHETTA (vedere pag. 156) LABEL (see on pg. 156)

## CARATTERISTICHE TECNICHE / TECHNICAL FEATURES

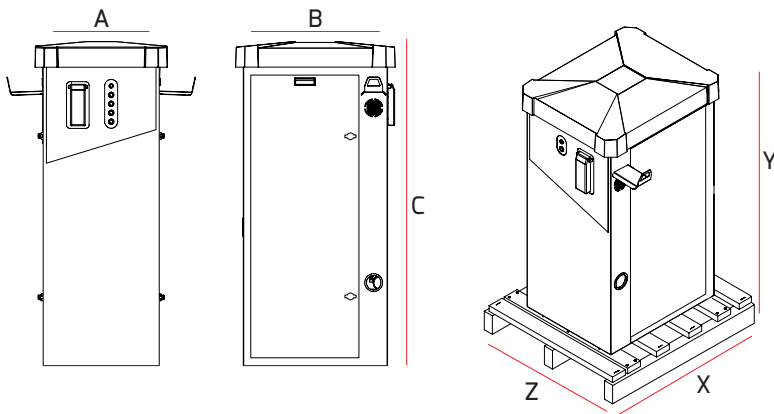
DIMENSIONI  
DIMENSIONS

A (mm)	B (mm)	C (mm)
592	714	1448

IMBALLO con PLURIBALL  
PACKAGING with PLURIBALL

X (mm)	Y (mm)	Z (mm)
900	1578	800

SCHEMA DI FISSAGGIO BASAMENTO  
INSTALLATION SCHEME

QUOTE (mm)      DIMENSIONS (mm)

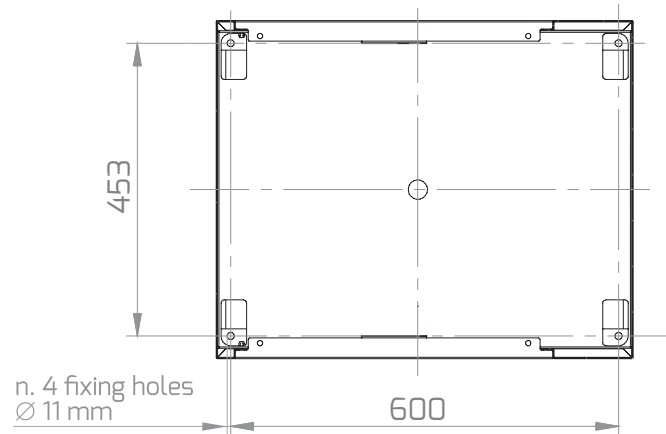

TENSIONE / VOLTAGE

230 V - 50 Hz

POTENZA / POWER

1,5 kW (senza compressore / without compressor) / 2 kW (con compressore / with compressor)

DEPRESSIONE / SUCTION

2300 mm/h<sub>2</sub>O

PESO TOTALE / TOTAL WEIGHT

80 kg

Codice  
Part No.Compressore  
Compressor

3030310001

3030310002





# AL WET

LAVAINTERNI SELF INIEZIONE · ESTRAZIONE / INJECTION · EXTRACTION CAR SEAT WASH

NEW



AVVIAMENTO MANUALE A RICHIESTA / MANUAL START ON DEMAND

COPERTURA IN ABS RESISTENTE AI RAGGI UV / ABS COVER, RESISTANT TO UV RAYS

PRODOTTO CHIMICO NON FORNITO / CHEMICAL PRODUCT NOT INCLUDED



NUOVI BIDONI IN ACCIAIO INOX  
NEW STAINLESS STEEL BINS



QUADRO ELETTRICO E GETTONIERA INTEGRATI  
INTEGRATED CONTROL BOARD

## ACCESSORI IN DOTAZIONE / SUPPLIED ACCESSORIES



N° N.	Codice Part No.	Descrizione Description
1	0964020005	TUBO COMPLETO LAVAINTERNI AL WET AL WET COMPLETE CAR SEAT WASH HOSE
2	0235020001	COPERTURA GETTONIERA COIN ACCEPTOR PROTECTION
3	0942611002	TESTATA ASPIRATORE CON BIDONE LAVAINTERNI VACUUM BIN WITH CAR SEAT WASH HEAD
4	0942011002	TESTATA LAVAINTERNI CAR SEAT WASH HEAD

## ACCESSORI A RICHIESTA / ACCESSORIES ON DEMAND



N° N.	Codice Part No.	Descrizione Description
1	0495022001	KIT EUROKEY NEXT EUROKEY NEXT KIT
2	0490211002	ILLUMINAZIONE LED LED LIGHT
3	0170242011	CASSETTO GETTONIERA LUCCHETTABILE
4	--	ETICHETTA (vedere pag. 156) LABEL (see on pg. 156)

## CARATTERISTICHE TECNICHE / TECHNICAL FEATURES

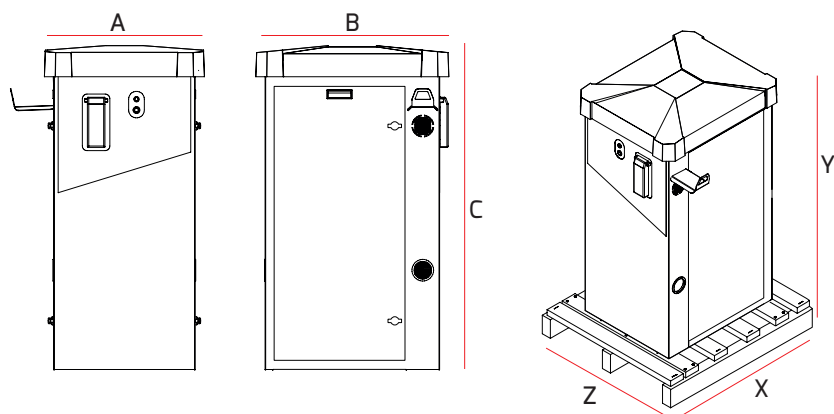
DIMENSIONI  
DIMENSIONS

A (mm)	B (mm)	C (mm)
592	714	1198

IMBALLO con PLURIBALL  
PACKAGING with PLURIBALL

X (mm)	Y (mm)	Z (mm)
900	1328	800

SCHEMA DI FISSAGGIO BASAMENTO  
INSTALLATION SCHEME

QUOTE (mm)      DIMENSIONS (mm)

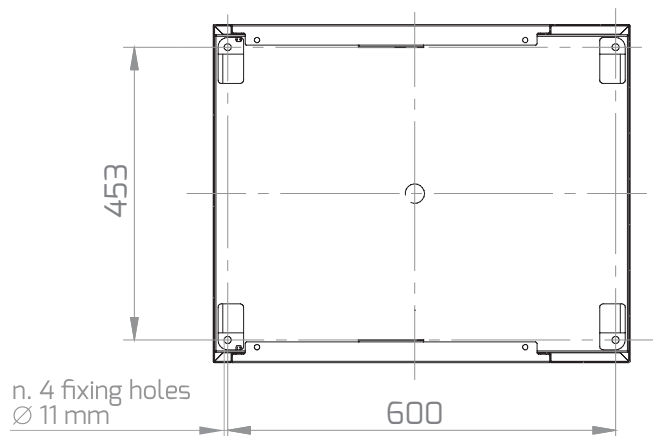

POTENZA / POWER	1,3 kW
TENSIONE / VOLTAGE	230 V - 50 Hz
DEPRESSIONE / SUCTION	2900 mm/h <sub>2</sub> O
PESO TOTALE / TOTAL WEIGHT	50 kg

Codice  
Part No.

3030450001

Aspiratore  
Vacuum

1,3 kW - 230 V