

2018



CATALOGO
CATALOGUE

**CAR WASH
EQUIPMENT**

GONFIAGOMME
TIRE INFLATOR

05 GONFIAGOMME TIRE INFLATOR

01	TI DIGITAL GONFIAGOMME DIGITALE · DIGITAL TIRE INFLATOR	077
02	TI WATER GONFIAGOMME ANALOGICO C/ACQUA · ANALOGIC TIRE INFLATOR W/WATER	081
03	TI ANALOGIC GONFIAGOMME ANALOGICO · ANALOGIC TIRE INFLATOR	085
04	LTI GONFIAGOMME ANALOGICO · ANALOGIC TIRE INFLATOR	089



L'**ACCIAIO INOX** che utilizziamo per le nostre macchine è del tipo AISI 304 quindi a basso contenuto di carbonio.
I principali vantaggi di questo materiale per le nostre applicazioni sono :

- Elevata resistenza alle intemperie e corrosione
- Facilità di ripulitura e ottimo coefficiente igienico.

The **STAINLESS STEEL** used in the construction of our machines is of the type AISI 304 with low carbon content.
The main advantages of this material for our applications are:

- High level of resistance to extreme weather and corrosion
- Ease of cleaning and maintenance and excellent hygiene properties.

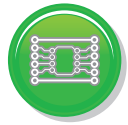

SCHEDA ELETTRONICA, dotata di temporizzatore elettronico, svolge una o più azioni a intervalli di tempo prefissati, facilmente regolabile secondo le esigenze del cliente.

The **ELECTRONIC CIRCUIT BOARD**, supplied with an electronic timer, manages one or more functions at prefixed intervals, and is easily adjustable according to the client's needs.



La **GETTONIERA ELETTRONICA**, offerta di serie, combina una straordinaria selettività ad un'estrema versatilità di programmazione.

The **ELECTRONIC TOKEN AND COIN-OP** mechanism, supplied as standard equipment, combines extraordinary versatility with extreme programming flexibility.



Il **MANOMETRO ANALOGICO** certificato, combina economicità a praticità e facilità d'uso.

The certified **ANALOGICAL PRESSURE GAUGE**, combines economic advantages, practicality and ease of use.



Il **DISPLAY DIGITALE** non è solo indicatore di pressione ma una vera e propria unità autonoma in grado di effettuare automaticamente le operazioni di gonfiaggio e sgonfiaggio dei pneumatici.

The **DIGITAL DISPLAY** is not only a pressure indicator, but also an authentic autonomous unit capable of automatically carrying out the functions of tire inflation and deflation.

TI - DIGITAL	TI - WATER	TI - ANALOGIC	LT - ANALOGIC
✓	✓	✓	✓
✓	✓	✓	✓
✓	✓	✓	✓
	✓	✓	✓
✓			

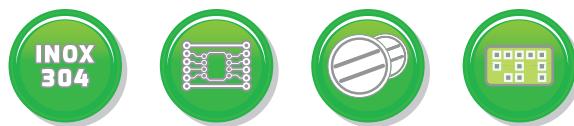

TI DIGITAL

GONFIAGOMME DIGITALE / DIGITAL TIRE INFLATOR

CARATTERISTICHE / FEATURES

STRUTTURA PORTANTE MODULARE / REINFORCED MODULAR FRAME

MANOMETRO DIGITALE CON OMOLOGAZIONI INTERNAZIONALI / DIGITAL PRESSURE GAUGE WITH INTERNATIONAL APPROVALS

CHIUSURA A DUE PUNTI ANTIVANDALO / VANDAL-PROOF DOORS AND LOCKS

CONTENITORE GETTONI LUCCHETTABILE / LOCKABLE TOKEN/COIN COMPARTMENT

TEMPO CICLO PROGRAMMABILE / PROGRAMMABLE CYCLE TIME

AVVIAMENTO MANUALE A RICHIESTA / MANUAL START ON DEMAND

CALOTTA IN ABS RESISTENTE AI RAGGI UV / ABS COVER, RESISTANT TO UV RAYS



QUADRO ELETTRICO E GETTONIERA INTEGRATI E DI FACILE ACCESSO
EASY ACCESS INTEGRATED CONTROL BOARD



OVE PREVISTO COMPRESSORE PROFESSIONALE VERTICALE CON
COMODO ACCESSO ALLO SCARICO DELLA CONDENZA
PROFESSIONAL VERTICAL COMPRESSOR (WHERE APPLICABLE) WITH
EASY ACCESS TO CONDENSATION DRAIN



PORTATUBO EASY-FIT
EASY-FIT HOSE HOLDER



PANNELLI LATERALI E POSTERIORE DI COPERTURA FACILMENTE
REMOVIBILI PER INTERVENTI DI MANUTENZIONE
LATERAL AND SIDE COVER PANELS ARE EASY TO REMOVE FOR
MAINTENANCE OPERATIONS

ACCESSORI IN DOTAZIONE / SUPPLIED ACCESSORIES

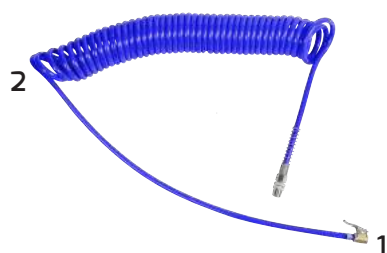

N° N.	Codice Part No.	Descrizione Description
1	0090020002	TESTINA DI GONFIAGGIO INFLATOR HEAD
2	0875034007	TUBO SPIRALATO 12 MT WIRE SPIRAL HOSE 12 MT

ACCESSORI A RICHIESTA / ACCESSORIES ON DEMAND

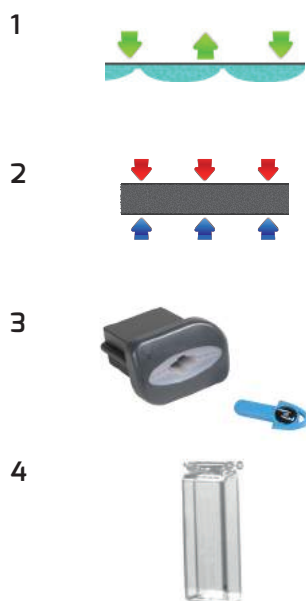

N° N.	Codice Part No.	Descrizione Description
1	0705610004	KIT ISOLAMENTO ACUSTICO SOUNDPROOFING KIT
2	0705610001	KIT ISOLAMENTO TERMICO HEAT INSULATION KIT
3	0495022001	KIT EUROKEY NEXT EUROKEY NEXT KIT
4	0235020001	COPERTURA GETTONIERA COIN ACCEPTOR PROTECTION

CARATTERISTICHE TECNICHE / TECHNICAL FEATURES

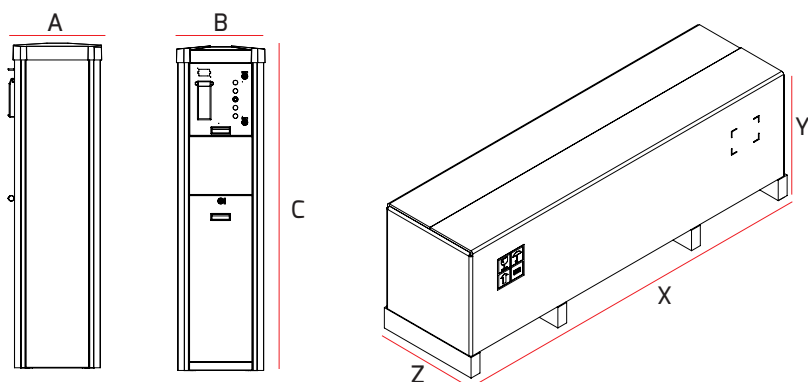
DIMENSIONI
DIMENSIONS

A (mm)	B (mm)	C (mm)
410	410	1550

IMBALLO
PACKAGING

X (mm)	Y (mm)	Z (mm)
1785	608	490

SCHEMA DI FISSAGGIO BASAMENTO
INSTALLATION SCHEME

QUOTE (mm) DIMENSIONS (mm)

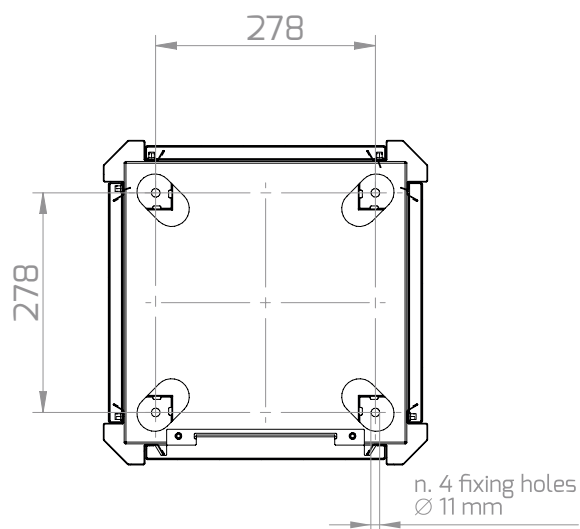

TENSIONE / VOLTAGE

230 V - 50 Hz

PORTATA D'ARIA / AIR FLOW

100 L/min

PRESSIONE ARIA / AIR PRESSURE

max 8 BAR

CAPACITÀ SERBATOIO COMPRESSORE / COMPRESSOR TANK CAPACITY

6 lt.

POTENZA / POWER

50W senza compressore / no compressor
450W con compressore / with compressor

PESO TOTALE / TOTAL WEIGHT

30 kg senza compressore / no compressor
40 kg con compressore / with compressor

Codice Part No.	Descrizione Description	Compressore Compressor
3070210001	TI DIGITAL	
3070210002	TI DIGITAL	✓

LE MACCHINE CON COMPRESSORE NON SONO FORNIBILI CON AVVIAMENTO MANUALE / THE MACHINES WITH COMPRESSOR ARE NOT AVAILABLE FOR FREE USE

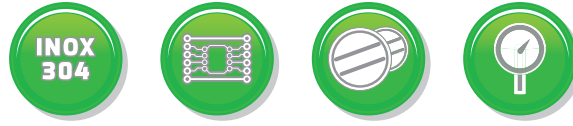

TI WATER

GONFIAGOMME ANALOGICO CON EROGAZIONE ACQUA / ANALOGIC TIRE INFLATOR WITH WATER DISPENSER

CARATTERISTICHE / FEATURES

STRUTTURA PORTANTE MODULARE / REINFORCED MODULAR FRAME

MANOMETRO ANALOGICO CON OMOLOGAZIONI INTERNAZIONALI / ANALOGIC PRESSURE GAUGE WITH INTERNATIONAL APPROVALS

CHIUSURA A DUE PUNTI ANTIVANDALO / VANDAL-PROOF DOORS AND LOCKS

CONTENITORE GETTONI LUCCHETTABILE / LOCKABLE TOKEN/COIN COMPARTMENT

TEMPO CICLO PROGRAMMABILE / PROGRAMMABLE CYCLE TIME

AVVIAMENTO MANUALE A RICHIESTA / MANUAL START ON DEMAND

CALOTTA IN ABS RESISTENTE AI RAGGI UV / ABS COVER, RESISTANT TO UV RAYS



QUADRO ELETTRICO E GETTONIERA INTEGRATI E DI FACILE ACCESSO
EASY ACCESS INTEGRATED CONTROL BOARD



OVE PREVISTO COMPRESSORE PROFESSIONALE VERTICALE CON
COMODO ACCESSO ALLO SCARICO DELLA CONDENSA
PROFESSIONAL VERTICAL COMPRESSOR (WHERE APPLICABLE) WITH
EASY ACCESS TO CONDENSATION DRAIN



PANNELLI LATERALI E POSTERIORE DI COPERTURA FACILMENTE
REMOVIBILI PER INTERVENTI DI MANUTENZIONE
LATERAL AND SIDE COVER PANELS ARE EASY TO REMOVE FOR
MAINTENANCE OPERATIONS

ACCESSORI IN DOTAZIONE / SUPPLIED ACCESSORIES



N° N.	Codice Part No.	Descrizione Description
1	0048020001	N.2 ARROTOLATORI CON TUBO 12 MT Ø 10 N.2 HOSE REELS WITH 12 MT Ø10 HOSE
2	0090020001	TESTINA DI GONFIAGGIO INFLATING HEAD
3	0937611002	PISTOLA EROGAZIONE ACQUA GUN FOR WATER SUPPLY

ACCESSORI A RICHIESTA / ACCESSORIES ON DEMAND

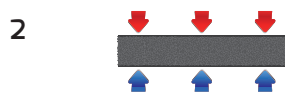

N° N.	Codice Part No.	Descrizione Description
1	0705610004	KIT ISOLAMENTO ACUSTICO SOUNDPROOFING KIT
2	0705610001	KIT ISOLAMENTO TERMICO HEAT INSULATION KIT
3	0445611003	KIT ANTIGELO NO FROST KIT
4	0495022001	KIT EUROKEY NEXT EUROKEY NEXT KIT
5	0235020001	COPERTURA GETTONIERA COIN ACCEPTOR PROTECTION

CARATTERISTICHE TECNICHE / TECHNICAL FEATURES

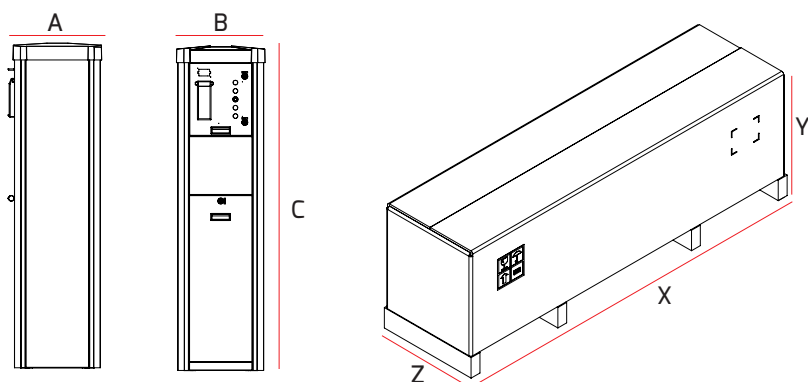
DIMENSIONI
DIMENSIONS

A (mm)	B (mm)	C (mm)
410	410	1550

IMBALLO
PACKAGING

X (mm)	Y (mm)	Z (mm)
1785	608	490

SCHEMA DI FISSAGGIO BASAMENTO
INSTALLATION SCHEME

QUOTE (mm) DIMENSIONS (mm)

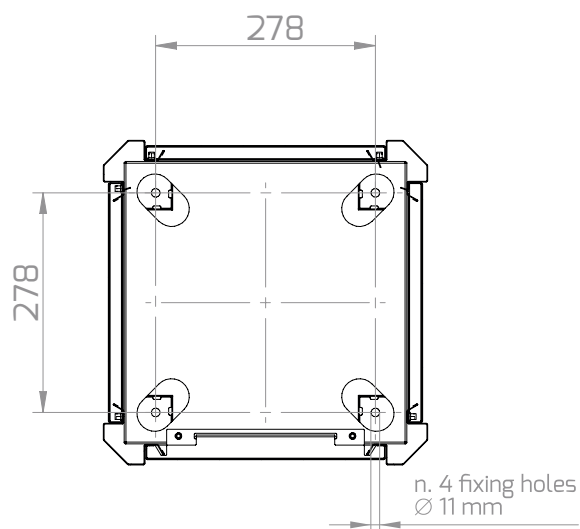

TENSIONE / VOLTAGE

230 V-50 Hz

PORTATA D'ARIA / AIR FLOW

100 L/min

PRESSIONE ARIA / AIR PRESSURE

max 8 BAR

CAPACITÀ SERBATOIO COMPRESSORE / COMPRESSOR TANK CAPACITY

6 lt.

POTENZA / POWER

50W senza compressore / no compressor
450W con compressore / with compressor

PESO TOTALE / TOTAL WEIGHT

30 kg senza compressore / no compressor
40 kg con compressore / with compressor

Codice Part No.	Descrizione Description	Compressore Compressor
3070310002	TI WATER	
3070310003	TI WATER	✓

LE MACCHINE CON COMPRESSORE NON SONO FORNIBILI CON AVVIAMENTO MANUALE / THE MACHINES WITH COMPRESSOR ARE NOT AVAILABLE FOR FREE USE



TI ANALOGIC

GONFIAGOMME ANALOGICO / ANALOGIC TIRE INFLATOR

CARATTERISTICHE / FEATURES

STRUTTURA PORTANTE MODULARE / REINFORCED MODULAR FRAME

MANOMETRO CERTIFICATO Ø63 mm / CERTIFIED PRESSURE GAUGE 63 mm

CHIUSURA A DUE PUNTI ANTIVANDALO / VANDAL-PROOF DOORS AND LOCKS

CONTENITORE GETTONI LUCCHETTABILE / LOCKABLE TOKEN/COIN COMPARTMENT

TEMPO CICLO PROGRAMMABILE / PROGRAMMABLE CYCLE TIME

AVVIAMENTO MANUALE A RICHIESTA / MANUAL START ON DEMAND

CALOTTA IN ABS RESISTENTE AI RAGGI UV / ABS COVER, RESISTANT TO UV RAYS



QUADRO ELETTRICO E GETTONIERA INTEGRATI E DI FACILE ACCESSO
EASY ACCESS INTEGRATED CONTROL BOARD



OVE PREVISTO COMPRESSORE PROFESSIONALE VERTICALE CON
COMODO ACCESSO ALLO SCARICO DELLA CONDENZA
PROFESSIONAL VERTICAL COMPRESSOR (WHERE APPLICABLE) WITH
EASY ACCESS TO CONDENSATION DRAIN

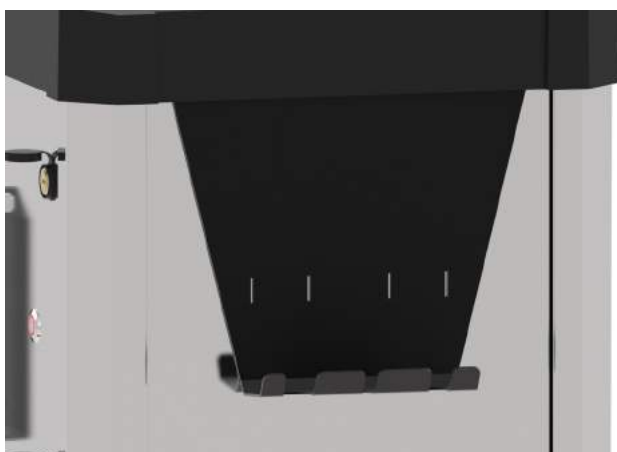

PORTATUBO EASY-FIT
EASY-FIT HOSE HOLDER



PANNELLI LATERALI E POSTERIORE DI COPERTURA FACILMENTE
REMOVIBILI PER INTERVENTI DI MANUTENZIONE
LATERAL AND SIDE COVER PANELS ARE EASY TO REMOVE FOR MAIN-
TENANCE OPERATIONS

ACCESSORI IN DOTAZIONE / SUPPLIED ACCESSORIES

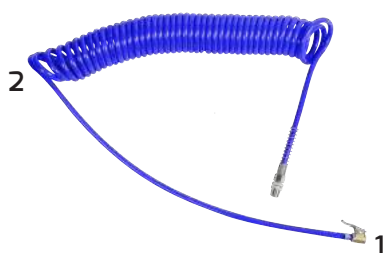

N° N.	Codice Part No.	Descrizione Description
1	0090020002	TESTINA DI GONFIAGGIO INFLATOR HEAD
2	0875034007	TUBO SPIRALATO 12 MT WIRE SPIRAL HOSE 12 MT

ACCESSORI A RICHIESTA / ACCESSORIES ON DEMAND

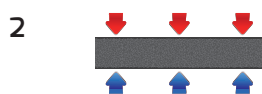

N° N.	Codice Part No.	Descrizione Description
1	0705610004	KIT ISOLAMENTO ACUSTICO SOUNDPROOFING KIT
2	0705610001	KIT ISOLAMENTO TERMICO HEAT INSULATION KIT
3	0495022001	KIT EUROKEY NEXT EUROKEY NEXT KIT
4	0235020001	COPERTURA GETTONIERA COIN ACCEPTOR PROTECTION

CARATTERISTICHE TECNICHE / TECHNICAL FEATURES

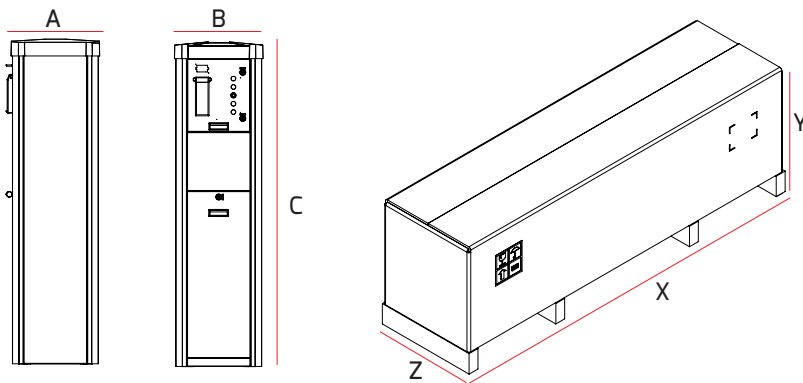
DIMENSIONI
DIMENSIONS

A (mm)	B (mm)	C (mm)
410	410	1550

IMBALLO
PACKAGING

X (mm)	Y (mm)	Z (mm)
1785	608	490

SCHEMA DI FISSAGGIO BASAMENTO
INSTALLATION SCHEME

QUOTE (mm) DIMENSIONS (mm)

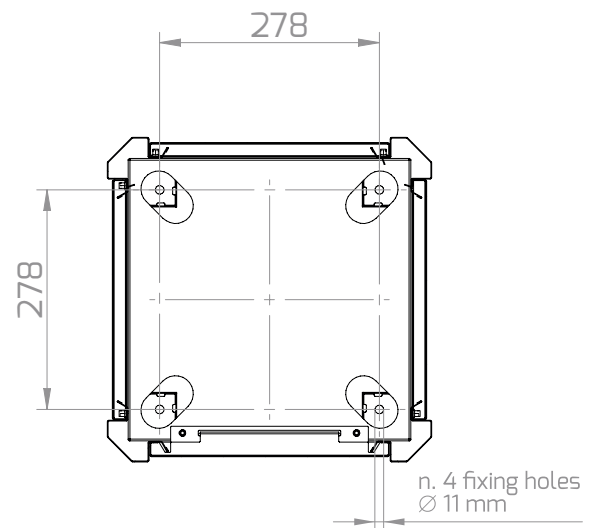

TENSIONE / VOLTAGE	230 V - 50 Hz	
PORTATA D'ARIA / AIR FLOW	100 L/min	
PRESSIONE ARIA / AIR PRESSURE	8 BAR	
POTENZA / POWER	50W senza compressore / no compressor	450W con compressore / compressor
PESO TOTALE / TOTAL WEIGHT	30 kg senza compressore / no compressor	40 kg con compressore / compressor

Codice Part No.	Descrizione Description	Compressore Compressor
3070110001	TI ANALOGIC	
3070110002	TI ANALOGIC	✓

LE MACCHINE CON COMPRESSORE NON SONO FORNIBILI CON AVVIAMENTO MANUALE / THE MACHINES WITH COMPRESSOR ARE NOT AVAILABLE FOR FREE USE

**LTI**

GONFIAGOMME ANALOGICO / ANALOGIC TIRE INFLATOR

NEW

ACCESSORI IN DOTAZIONE / SUPPLIED ACCESSORIES



N° N.	Codice Part No.	Descrizione Description
1	0090020002	TESTINA DI GONFIAGGIO INFLATOR HEAD
2	0875034007	TUBO SPIRALATO 12 MT WIRE SPIRAL HOSE 12 MT
3	0235020001	COPERTURA GETTONIERA COIN ACCEPTOR PROTECTION

ACCESSORI A RICHIESTA / ACCESSORIES ON DEMAND

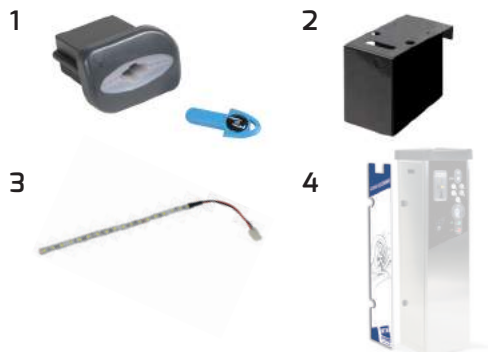

N° N.	Codice Part No.	Descrizione Description
1	0495022001	KIT EUROKEY NEXT EUROKEY NEXT KIT
2	0170242011	CASSETTO GETTONIERA LUCCHETTABILE LOCKABLE COIN COMPARTMENT
3	0490211003	ILLUMINAZIONE LED LED LIGHT
4	--	ETICHETTA (vedere pag. 156) LABEL (see on pg. 156)

CARATTERISTICHE TECNICHE / TECHNICAL FEATURES

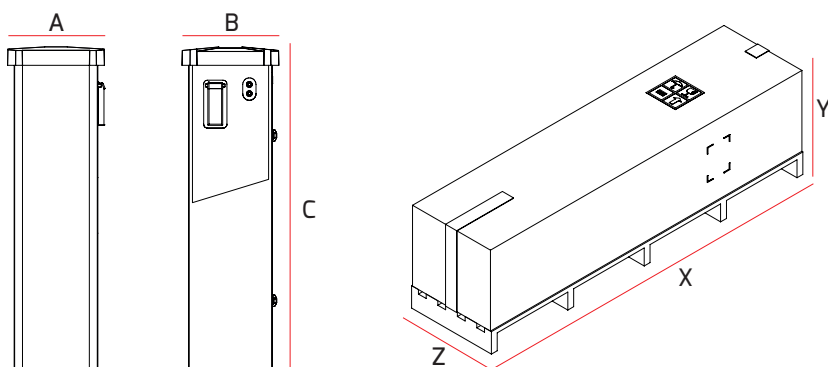
DIMENSIONI
DIMENSIONS

A (mm)	B (mm)	C (mm)
423	423	1414

IMBALLO
PACKAGING

X (mm)	Y (mm)	Z (mm)
1500	600	470

SCHEMA DI FISSAGGIO BASAMENTO
INSTALLATION SCHEME

QUOTE (mm)	DIMENSIONS (mm)
------------	-----------------

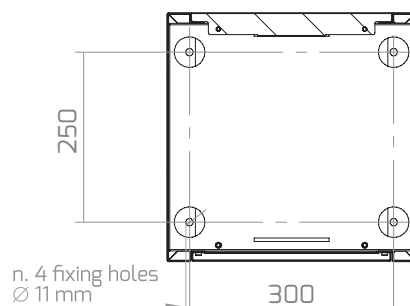

TENSIONE / VOLTAGE

230 V - 50 Hz

POTENZA / POWER

90W

PESO TOTALE / TOTAL WEIGHT

30 kg

Codice
Part No.

3070910001

Descrizione
Description

LTI