

2018



CATALOGO CATALOGUE

CAR WASH EQUIPMENT

COLONNINE EROGATRICI
DISPENSING COLUMNS

06 COLONNINE EROGATRICI DISPENSING COLUMNS

01	SD1 COLONNINA SINGOLO PRODOTTO · SINGLE PRODUCT COLUMN	095
02	LD1 COLONNINA SINGOLO PRODOTTO · SINGLE PRODUCT COLUMN	099
03	SD2 COLONNINE DOPPIO PRODOTTO · DOUBLE PRODUCTO COLUMNS	103
04	LD2 COLONNINE DOPPIO PRODOTTO · TWO PRODUCT COLUMNS	107
05	SD3 COLONNINE TRIPLO PRODOTTO · TRIPLE PRODUCT COLUMNS	109
06	SD1 PARFUME PROFUMO AUTO · CAR PERFUME	113
07	SD1 PARFUME POLAR PROFUMO AUTO · CAR PERFUME	115



L'**ACCIAIO INOX** che utilizziamo per le nostre macchine è del tipo AISI 304 quindi a basso contenuto di carbonio.
I principali vantaggi di questo materiale per le nostre applicazioni sono :

- Elevata resistenza alle intemperie e corrosione
- Facilità di ripulitura e ottimo coefficiente igienico.

The **STAINLESS STEEL** used in the construction of our machines is of the type AISI 304 with low carbon content.
The main advantages of this material for our applications are:

- High level of resistance to extreme weather and corrosion
- Ease of cleaning and maintenance and excellent hygiene properties.

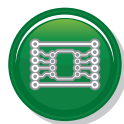

SCHEDA ELETTRONICA, dotata di temporizzatore elettronico, svolge una o più azioni a intervalli di tempo prefissati, facilmente regolabile secondo le esigenze del cliente.

The **ELECTRONIC CIRCUIT BOARD**, supplied with an electronic timer, manages one or more functions at prefixed intervals, and is easily adjustable according to the client's needs.



La **GETTONIERA ELETTRONICA**, offerta di serie, combina una straordinaria selettività ad un'estrema versatilità di programmazione.

The **ELECTRONIC TOKEN AND COIN-OP** mechanism, supplied as standard equipment, combines extraordinary versatility with extreme programming flexibility.



La **POMPA CENTRIFUGA IN ACCIAIO INOX** offerta nelle nostre colonnine erogatrici, garantisce una elevata affidabilità e resistenza contro l'aggressività di alcuni prodotti chimici.

The **STAINLESS STEEL CENTRIFUGAL PUMP** supplied in our dispensing columns, guarantees a high level of reliability and resistance against the harshness of some chemical products.



La **POMPA ELETTROMAGNETICA** offre un azionamento quasi privo di usura, capacità di resistenza, un ottimo rapporto qualità prezzo e basso consumo energetico.

The **ELECTROMAGNETIC PUMP** offers an almost wear-free functioning, resistance capacity, an optimal quality-price ratio and low energy consumption.



La nostra unità può gestire **4 DIVERSI TIPI DI PROFUMAZIONI** utilizzando una sola pistola erogatrice ed un solo tubo di mandata a 4 vie, garantendo che la fragranza scelta non possa mescolarsi mai con la precedente selezionata.

Our unit can manage **4 DIFFERENT TYPES OF FRAGRANCES** +using one single dispensing trigger and one single 4-way delivery tube, guaranteeing that the selected fragrance may never be tainted with the previous selection.



Le nostre colonnine erogatrici sono combinabili a scelta tra **NUMEROSE FUNZIONI E PRODOTTI DIVERSI** per soddisfare le più svariate necessità utilizzando una sola macchina a costi contenuti.

Our dispensing columns are combinable with choices among **NUMEROUS FUNCTIONS AND DIVERSE PRODUCTS** to satisfy the most diverse needs using only one machine at affordable costs.

	SD1	LD1	SD2	LD2	SD3	SD4 - PARFUME	SD4- PARFUME-P
L'ACCIAIO INOX che utilizziamo per le nostre macchine è del tipo AISI 304 quindi a basso contenuto di carbonio. I principali vantaggi di questo materiale per le nostre applicazioni sono : • Elevata resistenza alle intemperie e corrosione • Facilità di ripulitura e ottimo coefficiente igienico.	✓	✓	✓	✓	✓	✓	✓
The STAINLESS STEEL used in the construction of our machines is of the type AISI 304 with low carbon content. The main advantages of this material for our applications are: • High level of resistance to extreme weather and corrosion • Ease of cleaning and maintenance and excellent hygiene properties.	✓	✓	✓	✓	✓	✓	✓
SCHEDA ELETTRONICA, dotata di temporizzatore elettronico, svolge una o più azioni a intervalli di tempo prefissati, facilmente regolabile secondo le esigenze del cliente.	✓	✓	✓	✓	✓	✓	✓
The ELECTRONIC CIRCUIT BOARD, supplied with an electronic timer, manages one or more functions at prefixed intervals, and is easily adjustable according to the client's needs.	✓	✓	✓	✓	✓	✓	✓
La GETTONIERA ELETTRONICA, offerta di serie, combina una straordinaria selettività ad un'estrema versatilità di programmazione.	✓	✓	✓	✓	✓	✓	✓
The ELECTRONIC TOKEN AND COIN-OP mechanism, supplied as standard equipment, combines extraordinary versatility with extreme programming flexibility.	✓	✓	✓	✓	✓	✓	✓
La POMPA CENTRIFUGA IN ACCIAIO INOX offerta nelle nostre colonnine erogatrici, garantisce una elevata affidabilità e resistenza contro l'aggressività di alcuni prodotti chimici.	✓		✓	✓	✓		
The STAINLESS STEEL CENTRIFUGAL PUMP supplied in our dispensing columns, guarantees a high level of reliability and resistance against the harshness of some chemical products.	✓		✓	✓	✓		
La POMPA ELETTROMAGNETICA offre un azionamento quasi privo di usura, capacità di resistenza, un ottimo rapporto qualità prezzo e basso consumo energetico.	✓	✓	✓	✓	✓	✓	✓
The ELECTROMAGNETIC PUMP offers an almost wear-free functioning, resistance capacity, an optimal quality-price ratio and low energy consumption.	✓	✓	✓	✓	✓	✓	✓
La nostra unità può gestire 4 DIVERSI TIPI DI PROFUMAZIONI utilizzando una sola pistola erogatrice ed un solo tubo di mandata a 4 vie, garantendo che la fragranza scelta non possa mescolarsi mai con la precedente selezionata.						✓	✓
Our unit can manage 4 DIFFERENT TYPES OF FRAGRANCES +using one single dispensing trigger and one single 4-way delivery tube, guaranteeing that the selected fragrance may never be tainted with the previous selection.						✓	✓
Le nostre colonnine erogatrici sono combinabili a scelta tra NUMEROSE FUNZIONI E PRODOTTI DIVERSI per soddisfare le più svariate necessità utilizzando una sola macchina a costi contenuti.			✓	✓	✓		
Our dispensing columns are combinable with choices among NUMEROUS FUNCTIONS AND DIVERSE PRODUCTS to satisfy the most diverse needs using only one machine at affordable costs.			✓	✓	✓		



SD1

COLONNINA SINGOLO PRODOTTO / SINGLE PRODUCT COLUMN

CARATTERISTICHE / FEATURES

STRUTTURA PORTANTE MODULARE / REINFORCED MODULAR FRAME

CHIUSURA A DUE PUNTI ANTIVANDALO / VANDAL-PROOF DOORS AND LOCKS

CONTENITORE GETTONI LUCCHETTABILE / LOCKABLE TOKEN/COIN COMPARTMENT

TEMPO CICLO PROGRAMMABILE / PROGRAMMABLE CYCLE TIME

AVVIAMENTO MANUALE A RICHIESTA / MANUAL START ON DEMAND

CALOTTA IN ABS RESISTENTE AI RAGGI UV / ABS COVER, RESISTANT TO UV RAYS

PRODOTTI CHIMICI NON FORNITI / CHEMICAL PRODUCTS NOT INCLUDED



QUADRO ELETTRICO E GETTONIERA INTEGRATI E DI FACILE ACCESSO
EASY ACCESS INTEGRATED CONTROL BOARD



PORTATUBO EASY-FIT
EASY-FIT HOSE HOLDER



PANNELLI LATERALI E POSTERIORE DI COPERTURA FACILMENTE
REMOVIBILI PER INTERVENTI DI MANUTENZIONE
LATERAL AND SIDE COVER PANELS ARE EASY TO REMOVE FOR
MAINTENANCE OPERATIONS

COLONNINA UNIVERSALE PER EROGAZIONE DI PRODOTTI VARI
 PROFUMI SANITIZZANTI PRODOTTI CRUSCOTTO ANTIBATTERICO NEROGOMME PRODOTTO CERCHI

UNIVERSAL COLUMN DISPENSING VARIOUS PRODUCTS SUCH AS
 FRAGRANCES SANITIZERS DASHBOARD PRODUCTS ANTIBACTERIAL TIRE BLACKENING RIM SPRAY

ACCESSORI IN DOTAZIONE A SECONDA DELLA CONFIGURAZIONE SUPPLIED ACCESSORIES ACCORDING TO THE CONFIGURATION



1



2



3

N° N.	Codice Part No.	Descrizione Description
1	0875611003	PISTOLA NEBULIZZATRICE+TUBO SPIRALATO 8 MT NEBULIZING GUN+SPIRAL HOSE 8 MT
2	0875611004	PISTOLA PRODOTTO NEROGOMME+TUBO SPIRALATO 8 MT TIRE BLACKENING PRODUCT GUN+WIRE SPIRAL HOSE 8 MT
3	0875611005	PISTOLA PRODOTTO CERCHI+ TUBO SPIRALATO 8 MT RIM PRODUCT GUN+ WIRE SPIRAL HOSE 8 MT

ACCESSORI A RICHIESTA / ACCESSORIES ON DEMAND

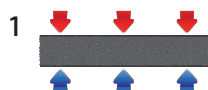

N° N.	Codice Part No.	Descrizione Description
1	0705610002	KIT ISOLAMENTO TERMICO HEAT INSULATION KIT
2	0705610003	KIT ANTIGELO NO FROST KIT
3	0495022001	KIT EUROKEY NEXT EUROKEY NEXT KIT
4	0235020001	COPERTURA GETTONIERA COIN ACCEPTOR PROTECTION

CARATTERISTICHE TECNICHE / TECHNICAL FEATURES

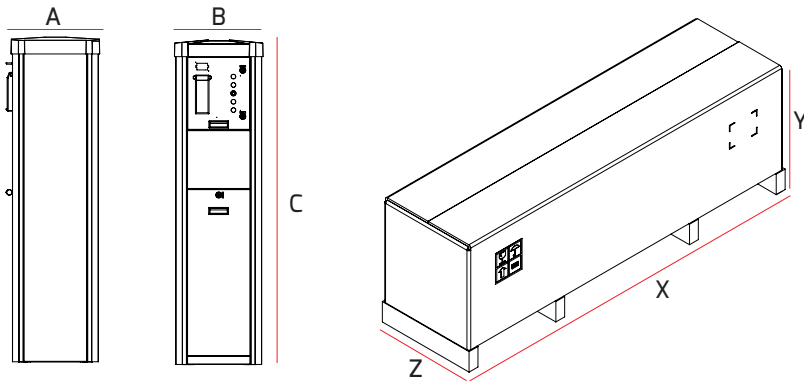
DIMENSIONI
DIMENSIONS

A (mm)	B (mm)	C (mm)
410	410	1550

IMBALLO
PACKAGING

X (mm)	Y (mm)	Z (mm)
1785	608	490

SCHEMA DI FISSAGGIO BASAMENTO
INSTALLATION SCHEME

QUOTE (mm) DIMENSIONS (mm)

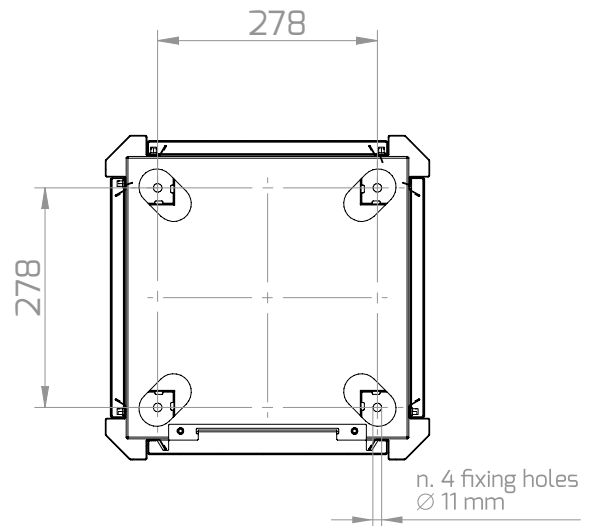
n. 4 fixing holes
Ø 11 mm

POMPA ELETTROMAGNETICA / ELECTROMAGNETIC PUMP

POMPA INOX / STAINLESS STEEL PUMP

TENSIONE / VOLTAGE	230 V - 50 Hz	230 V - 50 Hz
CAPACITÀ SERBATOIO / TANK CAPACITY	10 LT	32 LT
PORTATA POMPA / PUMP FLOW	0,08 L/min	3 L/min
EROGAZIONE PRODOTTO / PRODUCT SUPPLY	0,05 L/min	0,3 L/min

Codice Part No.	Descrizione Description	Potenza Power	Pompa Pump
3080410001	SD1 SPRAY	200 W	ELETTROMAGNETICA / ELECTROMAGNETIC
3080510002	SD1 TIRE	300 W	INOX / S.STEEL
3080510003	SD1 TIRE	200 W	ELETTROMAGNETICA / ELECTROMAGNETIC
3080910001	SD1 RIM	300 W	INOX / S.STEEL
3080910002	SD1 RIM	200 W	ELETTROMAGNETICA / ELECTROMAGNETIC

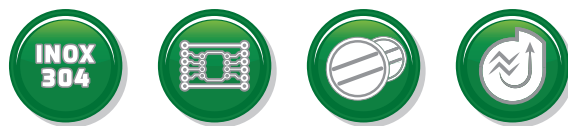

LD1

COLONNINA SINGOLO PRODOTTO / SINGLE PRODUCT COLUMN

NEW

CARATTERISTICHE / FEATURES

CHIUSURA A DUE PUNTI ANTIVANDALO / VANDAL-PROOF DOORS AND LOCKS

TEMPO CICLO PROGRAMMABILE / PROGRAMMABLE CYCLE TIME

AVVIAMENTO MANUALE A RICHIESTA / MANUAL START ON DEMAND

CALOTTA IN ABS RESISTENTE AI RAGGI UV / ABS COVER, RESISTANT TO UV RAYS

PRODOTTI CHIMICI NON FORNITI / CHEMICAL PRODUCTS NOT INCLUDED



PROFUMI COLONNINA UNIVERSALE PER EROGAZIONE DI PRODOTTI VARI
 SANITIZZANTI PRODOTTI CRUSCOTTO ANTIBATTERICO NEROGOMME

FRAGRANCES UNIVERSAL COLUMN DISPENSING VARIOUS PRODUCTS SUCH AS
 SANITIZERS DASHBOARD PRODUCTS ANTIBACTERIAL TIRE BLACKENING

ACCESSORI IN DOTAZIONE A SECONDA DELLA CONFIGURAZIONE
SUPPLIED ACCESSORIES ACCORDING TO THE CONFIGURATION



N° N.	Codice Part No.	Descrizione Description
1	0875611003	PISTOLA NEBULIZZATRICE+TUBO SPIRALATO 8 MT NEBULIZING GUN+SPIRAL HOSE 8 MT
2	0875611004	PISTOLA PRODOTTO NEROGOMME+TUBO SPIRALATO 8 MT TIRE BLACKENING PRODUCT GUN+WIRE SPIRAL HOSE 8 MT
3	0235020001	COPERTURA GETTONIERA COIN ACCEPTOR PROTECTION

ACCESSORI A RICHIESTA / ACCESSORIES ON DEMAND

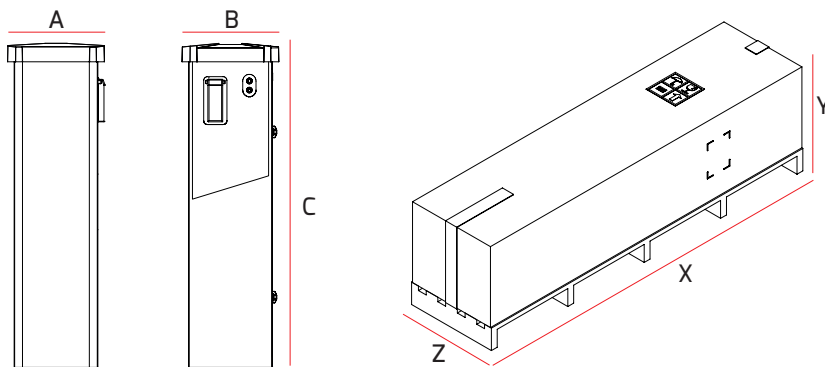

N° N.	Codice Part No.	Descrizione Description
1	0495022001	KIT EUROKEY NEXT EUROKEY NEXT KIT
2	0170242011	CASSETTO GETTONIERA LUCCHETTABILE LOCKABLE COIN COMPARTMENT
3	0490211003	ILLUMINAZIONE LED LED LIGHT
4	--	ETICHETTA (vedere pag. 156) LABEL (see on pg. 156)

DIMENSIONI
DIMENSIONS

A (mm)	B (mm)	C (mm)
423	423	1414

IMBALLO
PACKAGING

X (mm)	Y (mm)	Z (mm)
1500	600	470

SCHEMA DI FISSAGGIO BASAMENTO
INSTALLATION SCHEME

QUOTE (mm)	DIMENSIONS (mm)
------------	-----------------

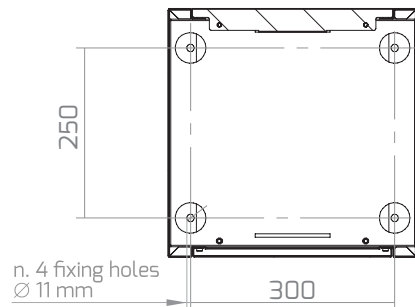

TENSIONE / VOLTAGE	230 V - 50 Hz
POTENZA / POWER	90W
PESO TOTALE / TOTAL WEIGHT	30 kg

Codice Part No.	Descrizione Description	Potenza Power	Pompa Pump
3084510001	LD1 SPRAY	200 W	ELETTROMAGNETICA / ELECTROMAGNETIC
3084510002	LD1 TIRE	200 W	ELETTROMAGNETICA / ELECTROMAGNETIC

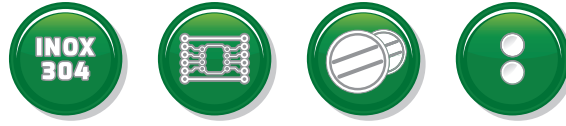

SD2

COLONNINA DOPPIO PRODOTTO / DOUBLE PRODUCT COLUMN

CARATTERISTICHE / CHARACTERISTICS

STRUTTURA PORTANTE MODULARE / REINFORCED MODULAR FRAME

POSSIBILITÀ DI IMPOSTARE DUE TEMPI PRODOTTO DIVERSI / CHOICE OF TWO DIFFERENT PRODUCT TIME SETTINGS

PASSAGGIO DA UN PRODOTTO ALL'ALTRO CON UN SOLO GETTONE CON RICALCOLO DEL TEMPO RESIDUO
SWITCHING FROM ONE PRODUCT TO ANOTHER WITH ONE SINGLE TOKEN WITH THE RECALCULATION OF REMAINING TIME

CHIUSURA A DUE PUNTI ANTIVANDALO / VANDAL-PROOF DOORS AND LOCKS

CONTENITORE GETTONI LUCCHETTABILE / LOCKABLE TOKEN/COIN COMPARTMENT

TEMPO CICLO PROGRAMMABILE / PROGRAMMABLE CYCLE TIME

CALOTTA IN ABS RESISTENTE AI RAGGI UV / ABS COVER, RESISTANT TO UV RAYS

PRODOTTI CHIMICI NON FORNITI / CHEMICAL PRODUCTS NOT INCLUDED

ACCESSORI IN DOTAZIONE / SUPPLIED ACCESSORIES

TUBI SPIRALATI COMPLETI A SECONDA DELLE FUNZIONI SCELTE DELLA MACCHINA
COMPLETE WIRE SPIRAL HOSES ACCORDING TO THE SELECTED FUNCTION OF THE MACHINE

ACCESSORI A RICHIESTA / ACCESSORIES ON DEMAND

1

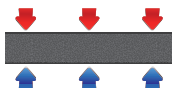

2



3



4



N° N.	Codice Part No.	Descrizione Description
1	0705610002	KIT ISOLAMENTO TERMICO HEAT INSULATION KIT
2	0705610003	KIT ANTIGELO NO FROST KIT
3	0495022001	KIT EUROKEY NEXT EUROKEY NEXT KIT
4	0235020001	COPERTURA GETTONIERA COIN ACCEPTOR PROTECTION

COMBINAZIONI DISPONIBILI / AVAILABLE COMBINATIONS

Tipo Type	ARIA COMPRESSA COMPRESSED AIR	SANITIZZANTE ANTIBACTERIAL SCENT	*PRODOTTO CERCHI *RIM PRODUCT	LUCIDA CRUSCOTTI DASHBOARD POLISH	*NERO GOMME *TIRE BLACKENING
01	✓	✓			
03	✓		✓		
04	✓			✓	
05	✓				✓
06		✓	✓		
07		✓		✓	
08		✓			✓
09			✓	✓	
10			✓		✓
11				✓	✓

*IL NEROGOMME e il PRODOTTO CERCHI, montando entrambi una pompa inox, NON sono abbinabili per motivi di spazio
 *The TIRE BLACKENING and the RIM PRODUCT can not be combined with both s/steel pumps, due to internal space issues

LE NOSTRE COLONNINE EROGATRICI **SD2** COMBINANO **2 SERVIZI/PRODOTTI** A SCELTA TRA QUELLI SOPRAELENCATI PER SODDISFARE LE PIÙ SVARIATE NECESSITÀ UTILIZZANDO UNA SOLA MACCHINA A COSTI CONTENUTI.

OUR **SD2** DISPENSING COLUMNS COMBINE A CHOICE OF **2 SERVICES/PRODUCTS** FROM THE ABOVE-MENTIONED ITEMS TO SATISFY THE MOST DIVERSE NEEDS USING ONLY ONE MACHINE AT AFFORDABLE COSTS

CARATTERISTICHE TECNICHE / TECHNICAL FEATURES

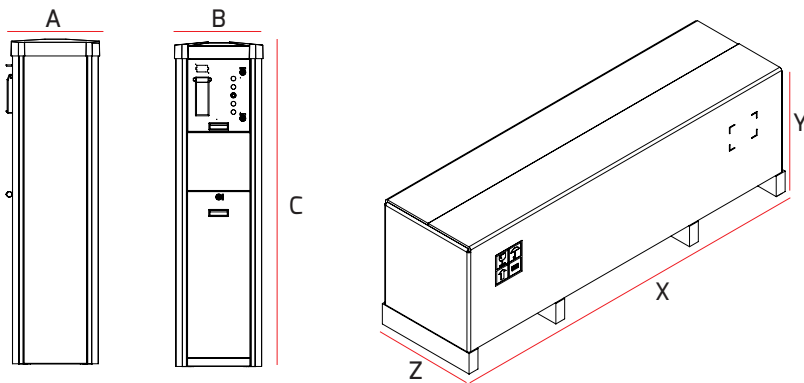
DIMENSIONI
DIMENSIONS

A (mm)	B (mm)	C (mm)
410	410	1550

IMBALLO
PACKAGING

X (mm)	Y (mm)	Z (mm)
1785	608	490

SCHEMA DI FISSAGGIO BASAMENTO
INSTALLATION SCHEME

QUOTE (mm) DIMENSIONS (mm)

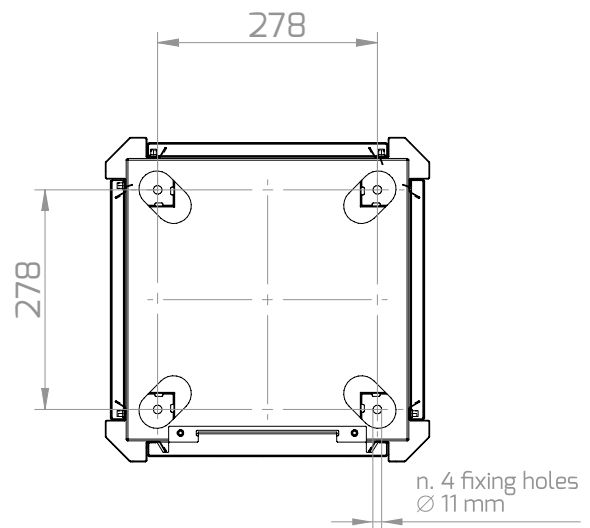

TENSIONE / VOLTAGE	230 V - 50 Hz
POTENZA / POWER	>100W <400W
PESO TOTALE / TOTAL WEIGHT	>30 kg <45 kg

Codice
Part No.Descrizione
DescriptionPompa
Pump

*

SD2

INOX / S.STEEL

*

SD2

ELETTROMAGNETICA / ELECTROMAGNETIC

* CODICE A SECONDA DELLA CONFIGURAZIONE
* ACCORDING TO THE CONFIGURATION

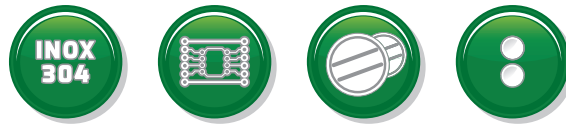

LD2

COLONNINA DOPPIO PRODOTTO / DOUBLE PRODUCT COLUMN

NEW

ACCESSORI IN DOTAZIONE / SUPPLIED ACCESSORIES

TUBI SPIRALATI COMPLETI A SECONDA DELLE FUNZIONI SCELTE DELLA MACCHINA
COMPLETE WIRE SPIRAL HOSES ACCORDING TO THE SELECTED FUNCTION OF THE MACHINE

1



N° N.	Codice Part No.	Descrizione Description
1	0235020001	COPERTURA GETTONIERA COIN ACCEPTOR PROTECTION

ACCESSORI A RICHIESTA / ACCESSORIES ON DEMAND

1



2



N° N.	Codice Part No.	Descrizione Description
1	0495022001	KIT EUROKEY NEXT EUROKEY NEXT KIT
2	0170242011	CASSETTO GETTONIERA LUCCHETTABILE LOCKABLE COIN COMPARTMENT

3



4



3	0490211003	ILLUMINAZIONE LED LED LIGHT
4		ETICHETTA (vedere pag. 156) LABEL (see on pg. 156)

CARATTERISTICHE TECNICHE / TECHNICAL FEATURES

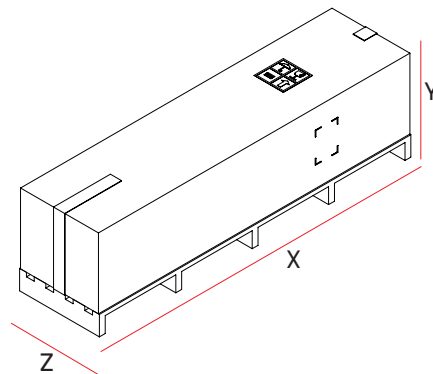
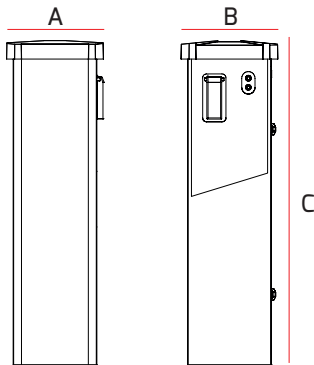
DIMENSIONI
DIMENSIONS

A (mm)	B (mm)	C (mm)
423	423	1414

IMBALLO
PACKAGING

X (mm)	Y (mm)	Z (mm)
1500	600	470

SCHEMA DI FISSAGGIO BASAMENTO
INSTALLATION SCHEME

QUOTE (mm) DIMENSIONS (mm)

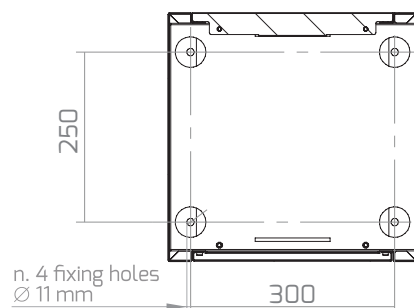

TENSIONE / VOLTAGE

230 V - 50 Hz

POTENZA / POWER

90W

PESO TOTALE / TOTAL WEIGHT

35 kg

Codice Part No.	ARIA COMPRESSA COMPRESSED AIR	PRODOTTO SPRAY SPRAY PRODUCT	NERO GOMME TIRE BLACKENING	Pompa Pump
3084610001	✓	✓		ELETTROMAGNETICA / ELECTROMAGNETICA
3084710001	✓		✓	ELETTROMAGNETICA / ELECTROMAGNETICA
3084810001		✓	✓	ELETTROMAGNETICA / ELECTROMAGNETICA

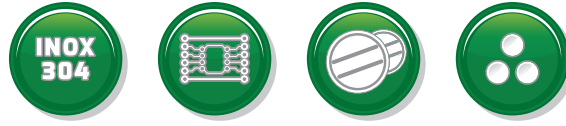

SD3

COLONNINA TRIPLO PRODOTTO / TRIPLE PRODUCT COLUMN

CARATTERISTICHE / CHARACTERISTICS

STRUTTURA PORTANTE MODULARE / REINFORCED MODULAR FRAME

POSSIBILITÀ DI IMPOSTARE DUE TEMPI PRODOTTO DIVERSI / CHOICE OF TWO DIFFERENT PRODUCT TIME SETTINGS

PASSAGGIO DA UN PRODOTTO ALL'ALTRO CON UN SOLO GETTONE CON RICALCOLO DEL TEMPO RESIDUO
SWITCHING FROM ONE PRODUCT TO ANOTHER WITH ONE SINGLE TOKEN WITH THE RECALCULATION OF REMAINING TIME

CHIUSURA A DUE PUNTI ANTIVANDALO / VANDAL-PROOF DOORS AND LOCKS

CONTENITORE GETTONI LUCCHETTABILE / LOCKABLE TOKEN/COIN COMPARTMENT

TEMPO CICLO PROGRAMMABILE / PROGRAMMABLE CYCLE TIME

CALOTTA IN ABS RESISTENTE AI RAGGI UV / ABS COVER, RESISTANT TO UV RAYS

PRODOTTI CHIMICI NON FORNITI / CHEMICAL PRODUCTS NOT INCLUDED

ACCESSORI IN DOTAZIONE / SUPPLIED ACCESSORIES

TUBI SPIRALATI COMPLETI A SECONDA DELLE FUNZIONI SCELTE DELLA MACCHINA
COMPLETE WIRE SPIRAL HOSES ACCORDING TO THE SELECTED FUNCTION OF THE MACHINE

ACCESSORI A RICHIESTA / ACCESSORIES ON DEMAND

1

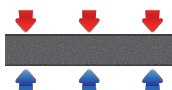

2



3



4



N° N.	Codice Part No.	Descrizione Description
1	0705610001	KIT ISOLAMENTO TERMICO HEAT INSULATION KIT
2	0445611003	KIT ANTIGELO NO FROST KIT
3	0495022001	KIT EUROKEY NEXT EUROKEY NEXT KIT
4	0235020001	COPERTURA GETTONIERA COIN ACCEPTOR PROTECTION

COMBINAZIONI DISPONIBILI / AVAILABLE COMBINATIONS

Tipo Type	ARIA COMPRESSA COMPRESSED AIR	SANITIZZANTE ANTIBACTERIAL SCENT	*PRODOTTO CERCHI *RIM PRODUCT	LUCIDA CRUSCOTTI DASHBOARD POLISH	*NERO GOMME *TIRE BLACKENING
01	✓	✓	✓		
02	✓	✓		✓	
03	✓	✓			✓
04	✓		✓	✓	
05	✓		✓		✓
06	✓			✓	✓

*IL NEROGOMME e il PRODOTTO CERCHI, montando entrambi una pompa inox, NON sono abbinabili per motivi di spazio
 *The TIRE BLACKENING and the RIM PRODUCT can not be combined with both s/steel pumps, due to internal space issues

LE NOSTRE COLONNINE EROGATRICI SD3 COMBINANO 2 SERVIZI/PRODOTTI A SCELTA TRA QUELLI SOPRAELENCATI
 OLTRE AL SERVIZIO ARIA COMPRESSA SEMPRE PRESENTE NELLA MACCHINA
 PER SODDISFARE LE PIÙ SVARIATE NECESSITÀ A COSTI CONTENUTI.

OUR SD3 DISPENSING COLUMNS COMBINE A CHOICE OF 2 SERVICES/PRODUCTS
 FROM THE ABOVE-MENTIONED ITEMS AS WELL AS COMPRESSED AIR SERVICE ALWAYS AVAILABLE IN THE MACHINE
 TO SATISFY THE MOST DIVERSE NEEDS AT AFFORDABLE COSTS

CARATTERISTICHE TECNICHE / TECHNICAL FEATURES

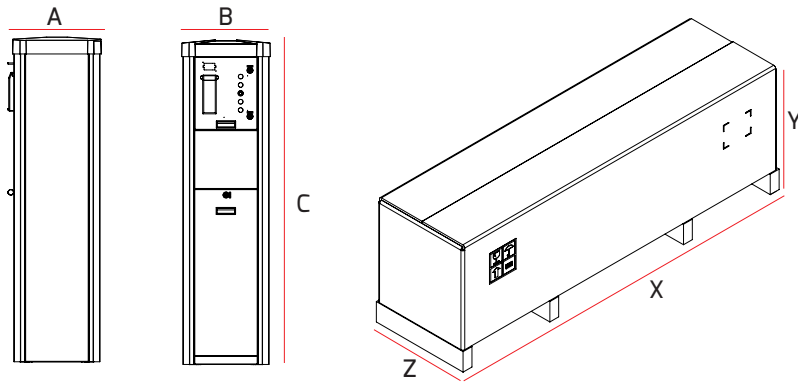
DIMENSIONI
DIMENSIONS

A (mm)	B (mm)	C (mm)
410	410	1550

IMBALLO
PACKAGING

X (mm)	Y (mm)	Z (mm)
450	1600	450

SCHEMA DI FISSAGGIO BASAMENTO
INSTALLATION SCHEME

QUOTE (mm) DIMENSIONS (mm)

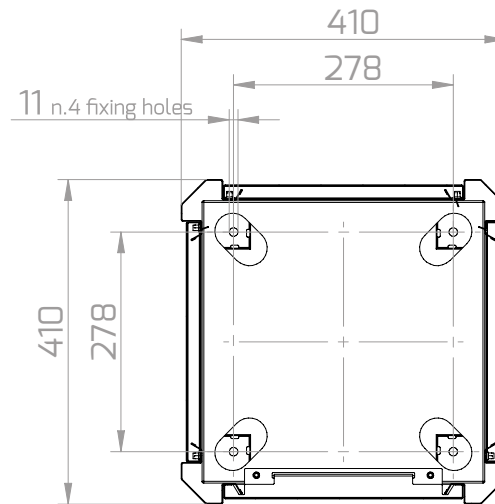

TENSIONE / VOLTAGE	230 V - 50 Hz
POTENZA / POWER	>100W <400W
PESO TOTALE / TOTAL WEIGHT	>30 kg <45 kg

Codice
Part No.Descrizione
DescriptionPompa
Pump

*

SD3

INOX / S.STEEL

*

SD3

ELETTROMAGNETICA / ELECTROMAGNETIC

* CODICE A SECONDA DELLA CONFIGURAZIONE
* PART NUMBER ACCORDING TO THE CONFIGURATION



SD1 PARFUME

PROFUMO AUTO / CAR PERFUME DISPENSER



La nostra unità può gestire **4 DIVERSI TIPI DI PROFUMAZIONI** utilizzando una sola pistola erogatrice ed un solo tubo di mandata a 4 vie, garantendo che la fragranza scelta non possa mescolarsi mai con la precedente selezionata.

Our unit can manage **4 DIFFERENT TYPES OF FRAGRANCES** using one single dispensing trigger and one 4-ways delivery hose, guaranteeing that the selected fragrance may never be tainted with the previous selection.

PRODOTTI CHIMICI NON FORNITI / CHEMICAL PRODUCTS NOT INCLUDED

ACCESSORI IN DOTAZIONE / SUPPLIED ACCESSORIES



N°	Codice	Descrizione
N.	Part No.	Description
1	0875611002	PISTOLA NEBULIZZATRICE+ TUBO SPIRALATO 8 MT NEBULIZING GUN+ WIRE SPIRAL HOSE 8 MT

ACCESSORI A RICHIESTA / ACCESSORIES ON DEMAND

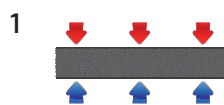

N°	Codice	Descrizione
N.	Part No.	Description
1	0705610001	KIT ISOLAMENTO TERMICO HEAT INSULATION KIT
2	0445611003	KIT ANTIGELO NO FROST KIT
3	0495022001	KIT EUROKEY NEXT EUROKEY NEXT KIT
4	0235020001	COPERTURA GETTONIERA COIN ACCEPTOR PROTECTION

CARATTERISTICHE TECNICHE / TECHNICAL FEATURES

PER DIMENSIONI E IMBALLI VEDERE SD1 PAGINA 095 / FOR DIMENSION AND PACKAGING SEE SD1 PAGE 095

TENSIONE / VOLTAGE	230 V - 50 Hz
CAPACITÀ SERBATOIO / TANK CAPACITY	4 x 5 LT
PORTATA POMPA / PUMP FLOW	3 L/min
EROGAZIONE PRODOTTO / PRODUCT SUPPLY	0,05 L/min

Codice	Descrizione	Potenza
Part No.	Description	Power
3080510002	SD1 PARFUME	300W



SD1 PARFUME POLAR

PROFUMO AUTO / CAR PERFUME DISPENSER



La nostra unità può gestire **4 DIVERSI TIPI DI PROFUMAZIONI** utilizzando una sola pistola erogatrice ed un solo tubo di mandata a 4 vie, garantendo che la fragranza scelta non possa mescolarsi mai con la precedente selezionata.

Our unit can manage **4 DIFFERENT TYPES OF FRAGRANCES** using one single dispensing trigger and one 4-ways delivery hose, guaranteeing that the selected fragrance may never be tainted with the previous selection.

PRODOTTI CHIMICI NON FORNITI / CHEMICAL PRODUCTS NOT INCLUDED

ACCESSORI IN DOTAZIONE / SUPPLIED ACCESSORIES

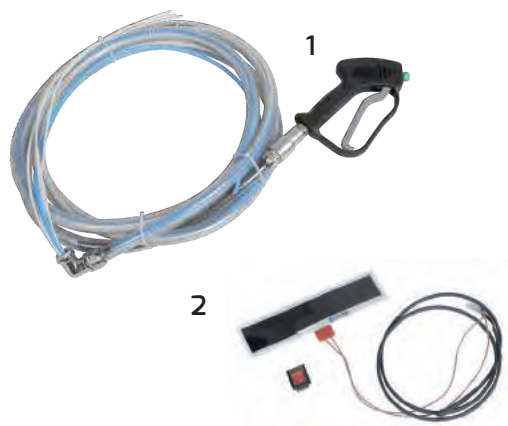

N° N.	Codice Part No.	Descrizione Description
1	0964511003	PISTOLA NEBULIZZATRICE+TUBO SPIRALATO 4 MT CON CAVO AUTOSCALDANTE NEBULIZING GUN+SPIRAL HOSE 4 MT WITH SELF-HEATING WIRE
2	0705610003	KIT ANTIGELO NO FROST KIT

ACCESSORI A RICHIESTA / ACCESSORIES ON DEMAND

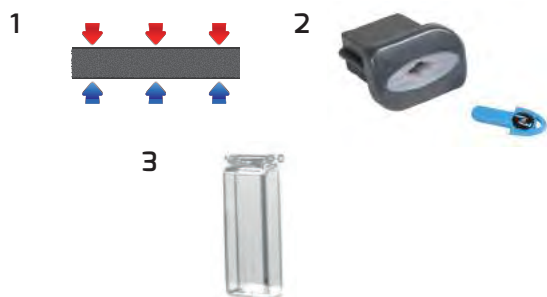

N° N.	Codice Part No.	Descrizione Description
1	0705610001	KIT ISOLAMENTO TERMICO HEAT INSULATION KIT
2	0495022001	KIT EUROKEY NEXT EUROKEY NEXT KIT
3	0235020001	COPERTURA GETTONIERA COIN ACCEPTOR PROTECTION

CARATTERISTICHE TECNICHE / TECHNICAL FEATURES

PER DIMENSIONI E IMBALLI VEDERE **SD1** PAGINA 095 / FOR DIMENSION AND PACKAGING SEE **SD1** PAGE 095

TENSIONE / VOLTAGE	230 V - 50 Hz
CAPACITÀ SERBATOIO / TANK CAPACITY	32 LT
PORTATA POMPA / PUMP FLOW	3 L/min
EROGAZIONE PRODOTTO / PRODUCT SUPPLY	0,05 L/min

Codice Part No.	Descrizione Description	Potenza Power
3080810004	SD1 PARFUME POLAR	400W